

NOTE: If the fuse panel on your 510063 61-64 Impala kit **HAS** a sticker like the photo at the left, you have the second design harness and your instructions are listed below and follow this page.



Number	Description
500332	Headlight Switch
500707	Fuse, Relay, and Flasher kit
500471	Courtesy Light kit
500684	Ignition Switch
500919	Practice Terminal Crimping Set
510530	Dash Harness kit
510532	Engine Wiring Kit
510533	Front Light Wiring kit
510531	Instrument Cluster Wiring kit
510073	Deck Lid - Rear Body kit
510761	Rear Body Wiring kit
510476	Alternator and main power Connection kit
510730	VSS Connection kit
500042	Floor Dimmer Switch
92968980	Firewall Mod. Template Sheet
92972581	Kit Introduction Instruction Sheet
92972582	Warning Sheet



www.americanautowire.com 856-933-0801

61-64 Impala Second Design Instructions

92972893 rev. 0.0 2/14/2020



WARNING:

Validate the kit contents with the component list included on page 2 of this sheet before proceeding. This kit is intended to be used in a modified vehicle. Please read this sheet thoroughly and be sure that you understand everything explained on it prior to opening any of the enclosed packages, or before attempting to install any of the components. Once this kit has been opened or a component installed, the kit is not returnable.

1. This kit should typically be used in a **MODIFIED** application only.
2. This kit supports the use of factory heater systems and aftermarket heater and A/C systems. The kit supplies power to a factory A/C control head but **DOES NOT** include the actual A/C harness for an original factory A/C vehicle. Factory original A/C harnesses are available under our Factory Fit product line as they are self contained harnesses made to fit and work with the stock A/C component configuration.
3. This kit requires the use of a high-current, self-exciting 1-wire alternator or other internally regulated alternator. An adapter may be necessary in some applications. The use of the stock, externally-regulated alternator or generator is **NOT** supported as these cannot handle the higher current requirements of updated ignition systems, electric fans, aftermarket A/C systems, stereo systems, air ride suspensions, and other power hungry accessories and will ultimately create performance issues with the system.
4. This kit **WILL NOT** support the use of a factory ammeter. All AAW kits are engineered to supply the optimum charge to the battery. To achieve this performance, we route our 6ga. charge wire directly from the alternator output charge terminal to the starter battery terminal. Due to the path of the charge being altered from the stock configuration, the gauge can no longer see a charge vs. a discharge, so it will not work properly. When ammeters were originally used, most generator or alternator current outputs were rated at a maximum of about 25-60 amps. Modified cars being built today typically utilize a 100 amp or higher output alternator. With these higher current units, ammeters, generally speaking, become a safety hazard. Ammeters are usually wired in parallel to the charging circuit, are typically unfused, and can short very easily causing a fire. A voltmeter is recommended as a good alternative.
5. This kit **IS NOT** set up with a resistance wire for a standard points-type ignition system. It is wired with a full 12 volt primary ignition feed that is hot in the run and crank position. Primary ignition voltage in the starting position is handled via a full 12 volt bypass wire. Our system will support HEI, MSD, other electronic ignition systems, as well as most all computerized Fuel Injection systems. If you wish to run a points type system, there are illustrations on the engine connection pages to do so. Extra parts (ballast resistor) that are not included in this kit will be required to complete that operation.
6. This kit **DOES NOT** include the rear body wiring, power rear window or tail light sockets for the station wagon, El Camino, or sedan delivery applications.



510063

510063 - Classic Update Series Kit 1961-64 Chevrolet Impala

This kit contains the following components:

<u>Bag</u>	<u>Part Number</u>	<u>Description</u>	<u>Quantity</u>
	500042	Floor Dimmer Switch	1
	500332	Headlight Switch	1
N	500471	Courtesy Light kit	1
	510632	Ignition Switch	1
	500707	Fuse, Relay, and Flasher kit	1
	500919	Practice Terminal Crimping Set	1
G	510530	Dash Harness kit	1
J	510532	Engine Wiring Kit	1
L	510533	Front Light Wiring kit	1
H	510531	Instrument Cluster wiring kit	1
M	510761	Rear Body Wiring kit	1
P	510073	Deck Lid wiring kit	1
V	510730	VSS Connection Kit	1
Z	510476	Alternator and Main Power Connection kit	1
	92968980	Firewall Modification Template	1
	92972581	Kit Introduction Instruction Sheet	1
	92972582	Warning Sheet	1

Validate the kit contents with this component list. If there are any discrepancies with incorrect or missing parts, stop your installation and notify the supplier you purchased the kit from before proceeding.



www.americanautowire.com 856-933-0801

510063

92972582 instruction sheet Rev 2.0 08/09/23

Classic Update Series

1961-1964 Impala

START HERE !

PLEASE READ THIS BEFORE STARTING INSTALLATION !

This wiring kit is designed for ease of installation. Please read the guidelines below, BEFORE STARTING your installation to guarantee a successful job!! Use an appropriate crimping tool which folds the crimp wings on the terminals as shown below. Top quality crimping tools are available from American Autowire or American Autowire authorized dealers.

NOTE: ALL TERMINALS THAT YOU INSTALL SHOULD BE PROPERLY SOLDERED. Our factory terminations are installed by GM approved termination presses, and soldering is not necessary on these terminations.



STEP 1: DISCONNECT YOUR BATTERY:
Disconnect the battery before installing the wiring kit to prevent any accidental shorting caused by loose bare wire ends.

STEP 2: START INSTALLING KIT:
This kit is broken down into individual steps that are identified by a letter printed on the instruction sheets visible through each bag. These letters are the order of operator for installing your kit. Start with the bag letter G, then H, etc. The order of installation is shown below.

- G 510530 Dash Harness Kit
- H 510531 Instrument Cluster Kit
- J 510532 Engine Kit
- L 510533 Front Light Kit
- M 510761 Rear Body Kit
- N 500471 Courtesy Light Kit
- P 510073 Trunk Lid Kit
- V 510730 VSS Connection Kit
- Z 510476 Alternator and Main Connection Kit

STEP 3: RECONNECT YOUR BATTERY:
When you have completed the installation and are ready to reconnect the battery, make sure that the following electrical system grounds are in place:

- A. Battery is grounded to the ENGINE BLOCK.
- B. Battery is grounded to the frame.
- C. Engine block is grounded to the frame.
- D. Body is grounded to the frame.

STEP 4: CHECK ALL ELECTRICAL FUNCTIONS:
Any non-functioning items should be checked for proper installation. Any problems with your wiring and electrical circuit functions should be addressed to American Autowire Systems, Inc. as soon as possible to avoid any warranty problems.

If you have any questions concerning this or any of our products, please feel free to call us at 1-800-482-WIRE.

AMERICAN AUTOWIRE MAKES IT EASY !!

We carry many accessories for your 61-64 Impala

p/n R0067108
OEM style non-stick harness tape



p/n 01998728 (61-2)
p/n 01997929 (63)
p/n 01993661 (64)
Muncie 4 speed back up lamp switch.



p/n 38131
Breakerless Ignition Module,
GM V-8 POINT CONVERSION KIT



OEM style wiper switch.

p/n 01993543 (59-63) 2 spd w/washer
p/n 01993541 (59-63) 1 spd w/washer
p/n 01993643 (64) 2 spd w/washer

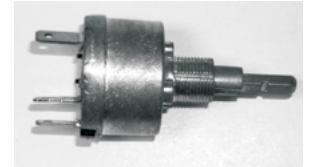

p/n 510585 OEM multi
terminal crimping tool
(20-14 gauge).



p/n 510586 OEM large
gauge terminal and double
crimping tool (20-8 gauge).



p/n 36320 (1961)
p/n 36321 (1962)
p/n 36322 (1963)
p/n 36323 (1964)

Factory assembly manual.
(It's what they used on the assembly
line to build your Impala!)

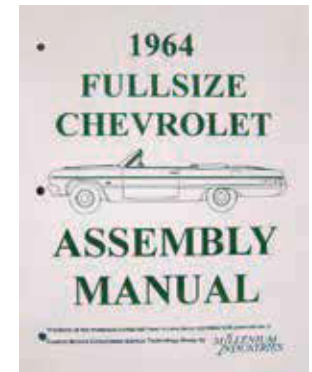

THIS KIT DOES NOT SUPPORT STOCK (ORIGINAL) GENERATORS. THE DESIGN OF THE KIT IS DESIGNED TO SUPPLY MORE POWER THAN A GENERATOR IS CAPABLE OF SUPPLYING.



www.americanautowire.com 856-933-0801

Classic Update
Series

1961-1964 Impala

510063

© COPYRIGHT 2004 American Autowire / Factory-Fit
Used with express permission of
American Autowire / Factory-Fit
92972581 instruction sheet rev. 0.0 10/3/2019

CLASSIC UPDATE SERIES

1961-64 IMPALA



www.americanautowire.com 856-933-0801

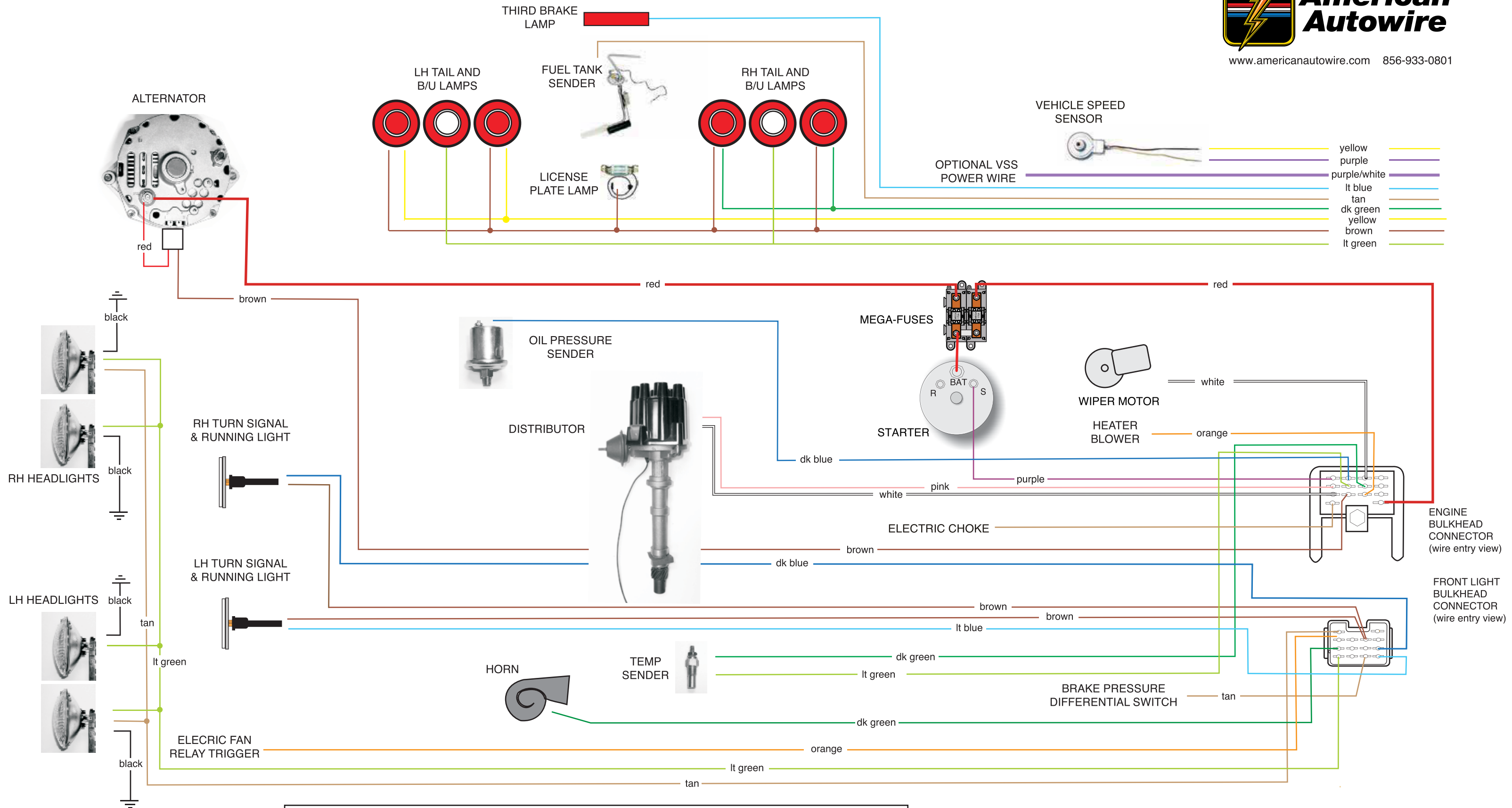

NOTICE: This schematic drawing is for reference only! DO NOT use the schematc to install this wiring kit. Use the instruction sheets that are included in each of the separate sub-kit bags as they include directions for proper terminations, and various specific applications.

510063

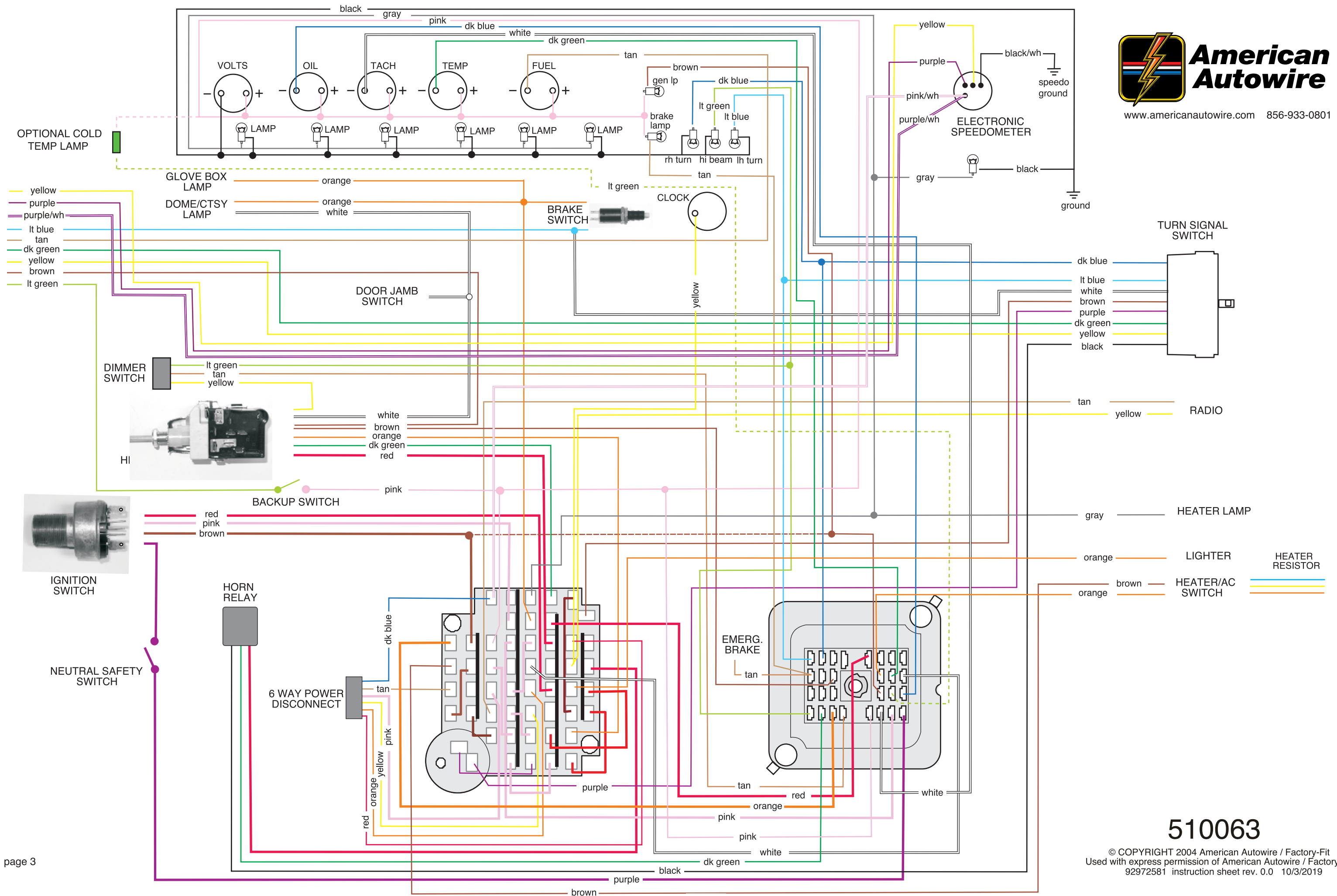

510063

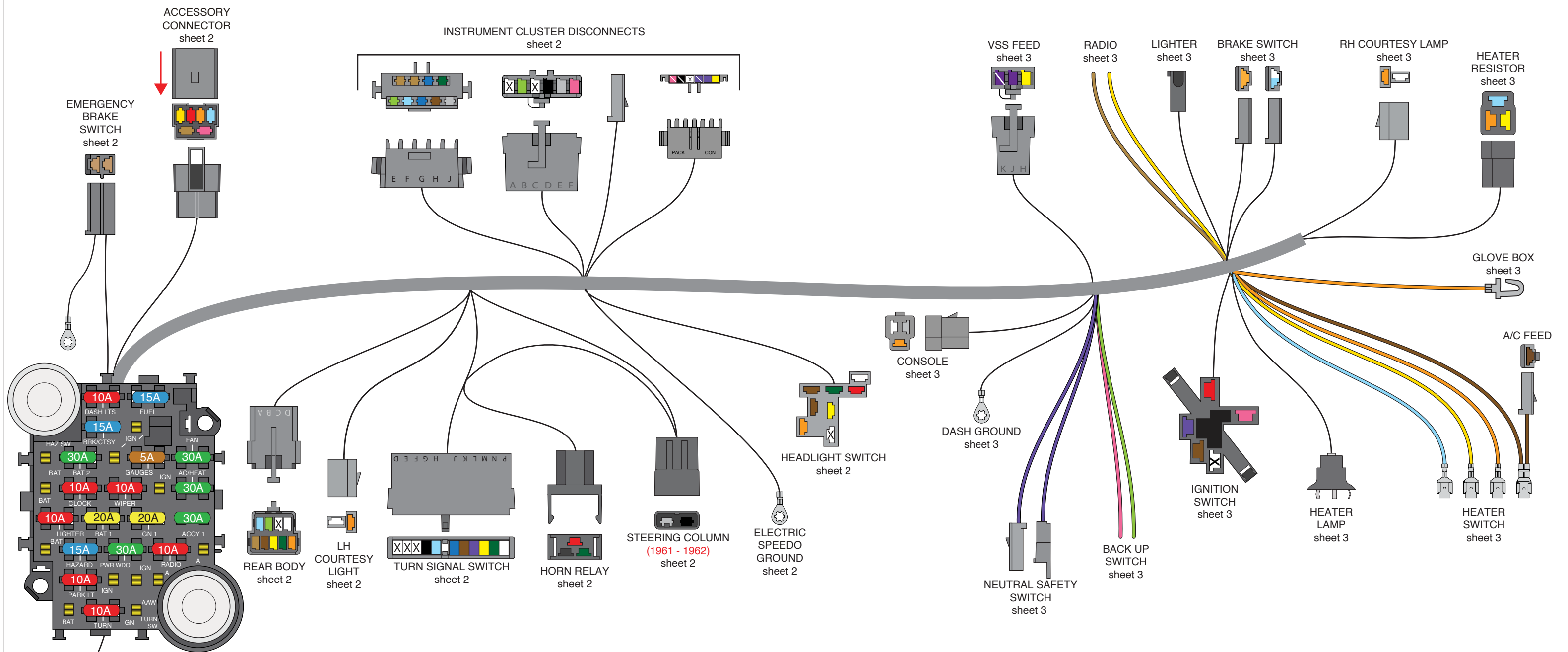

Dash Kit Installation Instructions

Following these instructions will guarantee a successful installation of your American Autowire fuse panel harness.

1. Study the diagram above to familiarize yourself with the dash harness.
2. Modify your firewall opening and install the fuse box (see "INSTALLING THE FUSE BOX" on sheet 2, and the 92968980 template).
3. Route the dash harness using the factory support straps.
4. Make all connections as shown on the following pages of this dash harness kit.
5. Once this harness is installed, continue to bag 'H', and install the rest of the kit (bags H,J,K,L,M).

DIMMER SWITCH sheet 2



**American
Autowire**

www.americanautowire.com 856-933-0801

1961-64 Impala

bag
G

DASH KIT
510530

92972552 instruction rev 2.0 JDM 05/12/2023

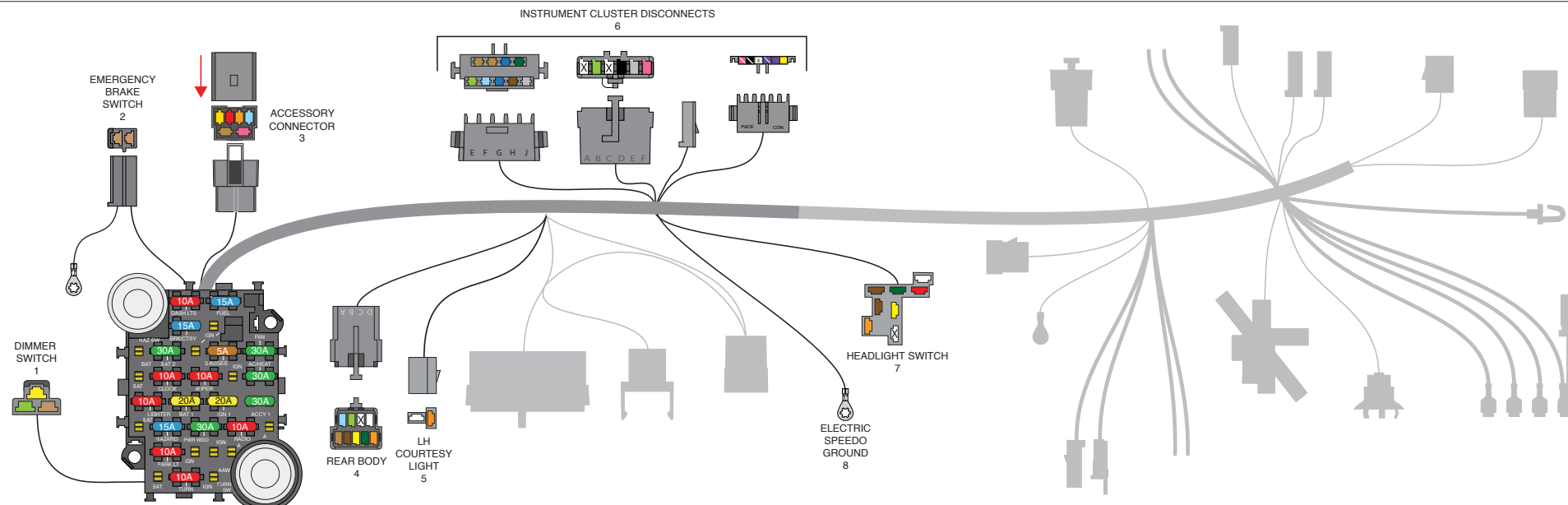

1. DIMMER SWITCH
 This connector will mate to the floor mounted dimmer switch.
 Yellow 12 volt feed into dimmer switch from Headlight Switch
 Light Green 12 volt feed out to high beam on Headlight Switch
 Tan 12 volt feed out to low beam on Headlight Switch
2. EMERGENCY BRAKE
 Tan Connect to the emergency brake switch. This is the ground circuit to the cluster assembly for the brake warning lamp.
 Tan Connect to the emergency brake switch. Connect the wire with the ring terminal to a good chassis ground.
3. ACCESSORIES
 Use connector J and included terminals S (shown to the right of this sheet) for wires to be added to the in-dash accessory connector pigtail. The mating connector "J" for these circuits will be pre-inserted into the dash pigtail, and terminals can be located in the dash loose piece kit along with the fuse panel mounting hardware.
NOTE: Not all installations will require use of these connections. It was added to your kit as a convenient source for 12 volt power.

	Fuse	Rating	
Dark Blue	FUEL	15 amp	Fused 12 volt IGNITION feed for fuel pump (may also be used to feed power to another ignition circuit)
Orange	BAT1	20 amp	Fused 12 volt BATTERY feed for power seats (may also be used to feed power to another battery circuit)
Red	BAT2	30 amp	Fused 12 volt BATTERY feed for power door locks (may also be used to feed power to another accessory circuit)
Pink	IGN1	20 amp	Fused 12 volt IGNITION feed for cruise control (may also be used to feed power to another ignition circuit)
Yellow	PWRWDO	30 amp	Fused 12 volt IGNITION feed for power windows (may also be used to feed power to another ignition circuit)
Tan	ACCY1	30 amp	Fused 12 volt ACCESSORY feed (may also be used to feed power to an accessory circuit)
4. REAR BODY
 This connector will mate to the connector from the Rear Body harness found in bag M.
 Tan Fuel tank sender lead
 Brown Tail lamp feed
 Yellow LH turn / brake feed
 Dark Green RH turn / brake feed
 Orange Dome / courtesy lamp feed
 White Dome / courtesy lamp ground
 Light Green Back up lamp feed
 Light Blue Third brake light
5. LH COURTESY LAMP
 Plug this connector into the mating connector from the courtesy lamp kit bag N (500471).
Note: If you are working on a 1963 or 1964 vehicle, a loose piece terminal has been provided in this dash kit for you to crimp onto the door jamb switch wire.
 Orange 12 volt battery feed fo lamp
 White Ground circuit for lamp
6. INSTRUMENT CLUSTER DISCONNECTS
 These connectors will plug into the gauge disconnect harness from bag H (510531).
 Wire identifications are described on the instruction sheets from bag H (510531).
7. HEADLIGHT SWITCH
NOTE: We suggest notching out a new key slot on your dash cluster at about 10 o'clock (as seen to the right) to help clear the headlight switch connection behind the dash
 Red 12 volt feed to switch 'BAT' location on headlight switch
 Orange 12 volt feed 'in' to park/tail 'PARK / TAIL FEED IN' location on headlight switch (commonly found on GM headlight switches).
 Brown Park lamp feed 'out' 'PARK LAMP OUT' location on headlight switch.
 Yellow Dimmer feed 'DIMMER FEED' location on headlight switch.
 Dk Green Instrument lamp feed' INSTRUMENT LAMP' location on headlight switch.
 White Dome / courtesy ground 'GROUND' location on headlight switch.
8. ELECTRIC SPEEDO GROUND
 Connect to a good chassis ground. This ground must be at a different location than the DASH GROUND.

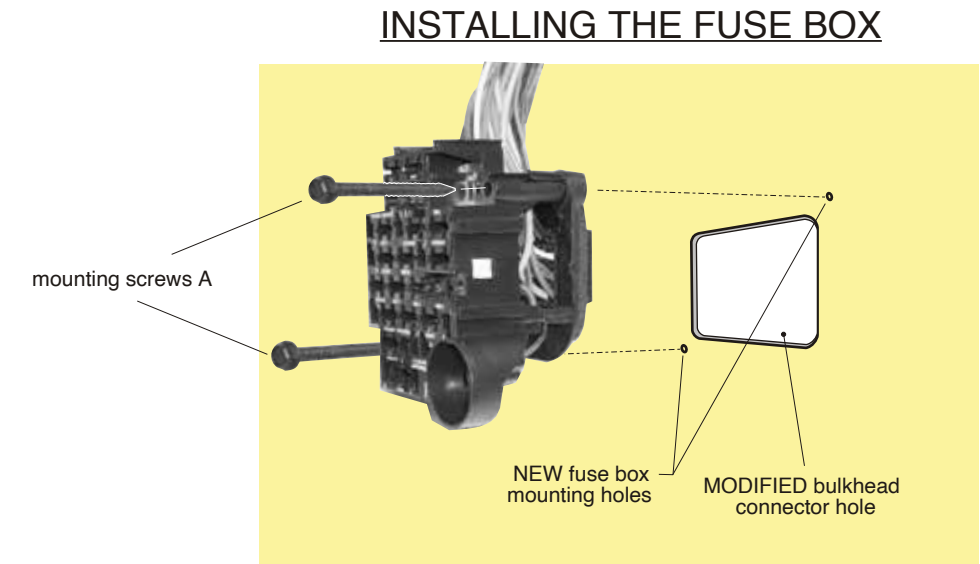

1. Locate the stock OEM bulkhead hole in the driver side of the firewall.
NOTE: You will need to modify the opening in the firewall by making it larger. See firewall template 92968980 to help with this operation.
2. Mount the fuse box with the flasher can in the bottom right corner, as shown above.
3. Using the two mounting screws A, attached the fuse panel to the firewall.

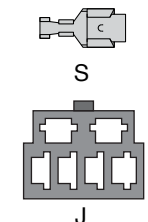

Example showing new notch for headlight switch:



www.americanautowire.com 856-933-0801



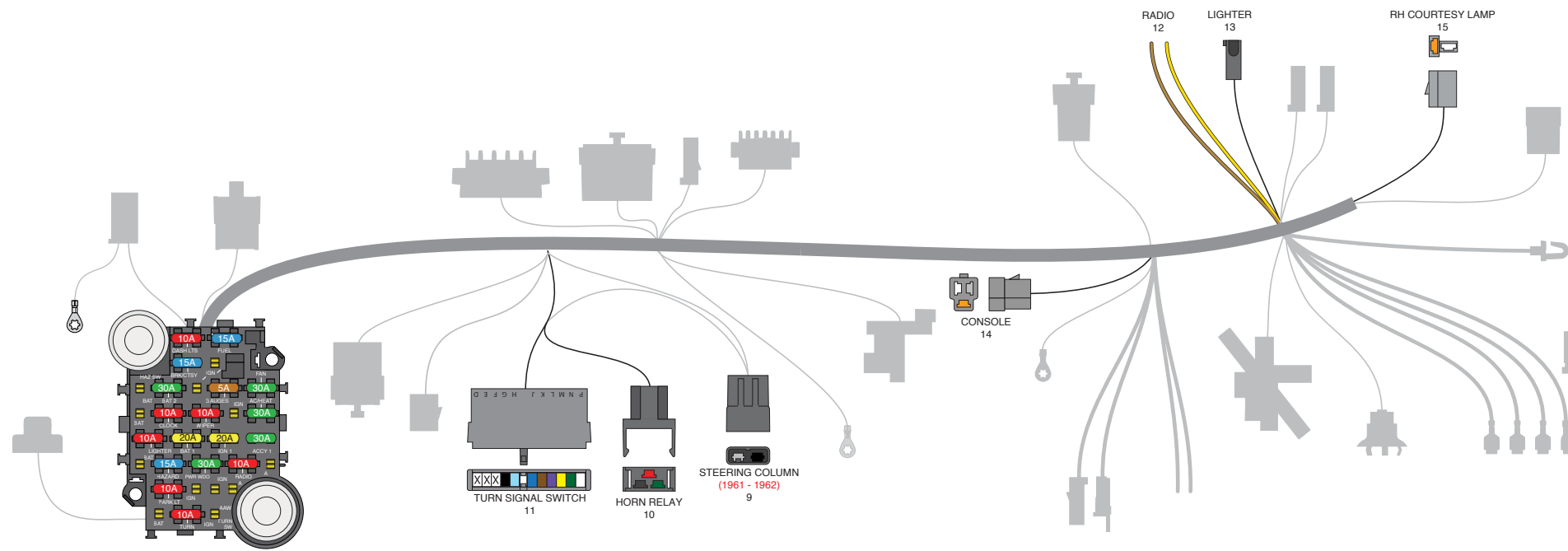

- 9. STEERING COLUMN CONNECTION (1961-62 only)

Gray	Transmission selector lamp wire for column automatic cars.
Black	Horn relay ground wire if using stock 1961-62 column.
- 10. HORN RELAY

Plug the horn relay (found in the fuse bag) into this connector.	
Red	12 volt battery
Black	Relay ground circuit (to steering column)
Dk Green	Triggered 12 volts to horn
- 11. TURN SIGNAL SWITCH

This harness is set up for a 1969-74 GM or Ididit Steering column utilizing a 3 7/8" turn signal switch connector. If you are using your car's original column, we have provided you with the proper connector (L) and terminals (M) for you to cut your existing connector off of your 1963-64 steering column and adapt it into our new dash harness. For a 1961-62 car, the turn signal switch is a mechanical unit mounted on top of the column up under the dash. There was no electrical wiring coming from the switch as your original dash harness contained the connector that plugged directly into the switch. A new connector pigtail is included to build an adapter that will allow for the use of the original 1961-62 mechanical turn signal switch. The adapter will use the same connector and terminals as the 1963-64 configuration mentioned above to connect to the under dash harness. If using a 1975 or later GM steering column or an after-market steering column using a GM turn signal switch with the 4-1/4" GM turn signal connector, it will be necessary to replace the 4 1/4" turn signal switch connector with the included 3 7/8" connector L, matching wires by color.

White	12 volt feed from brake switch
Dark Green	RH tail lamp
Yellow	LH tail lamp
Purple	12 volt feed from turn flasher
Brown	12 volt feed from hazard flasher
Dark Blue	RH front park lamp
Light Blue	LH front park lamp
Black	Horn relay ground wire to horn switch (1963-64)
- 12. RADIO

Tan	Radio accessory feed.
Yellow	Radio 12 volt clock lead (battery feed)
- 13. LIGHTER

Orange	Connect to lighter. (battery feed)
--------	------------------------------------
- 14. CONSOLE CONNECTION

These wires are for use on a console vehicle.	
Orange	12 volt battery feed
Grey	Console illumination lamp
White	Courtesy ground
- 15. RH COURTESY LAMP

Plug this connector into the mating connector from the courtesy lamp kit bag N, 500471.	
Special Note: If you are working on a 1963 or 1964 vehicle, a loose piece terminal has been provided in this dash kit for you to crimp onto the door jamb switch wire.	
Orange	12 volt battery feed fo lamp
White	Ground circuit for lamp

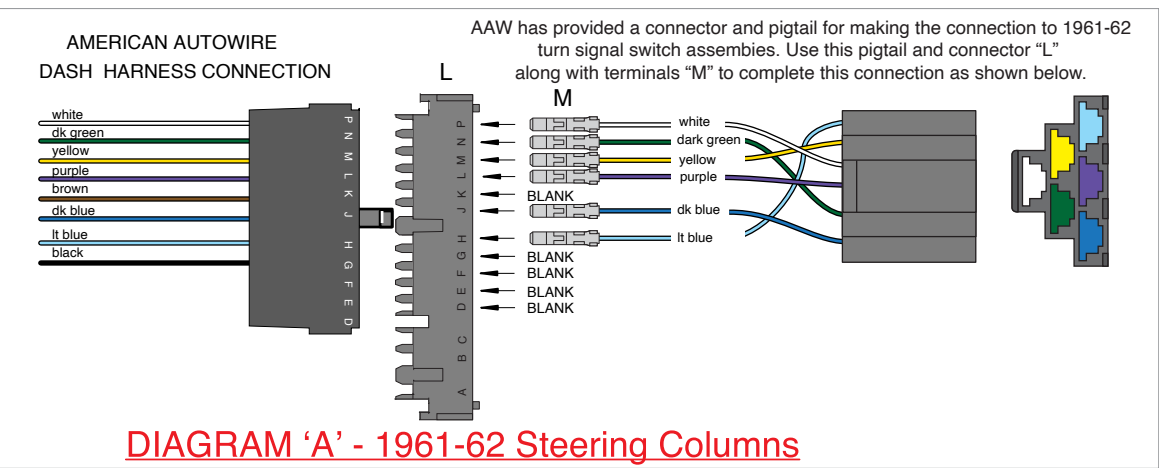

DIAGRAM 'A' - 1961-62 Steering Columns

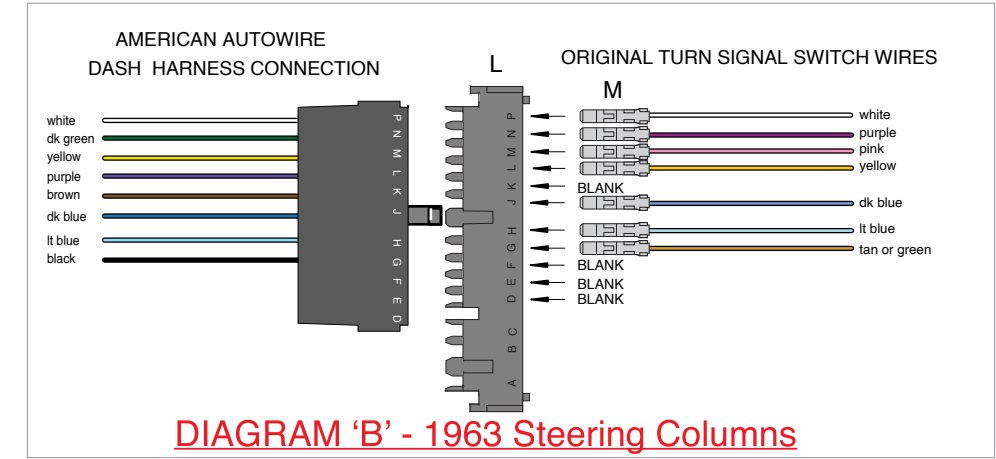

DIAGRAM 'B' - 1963 Steering Columns

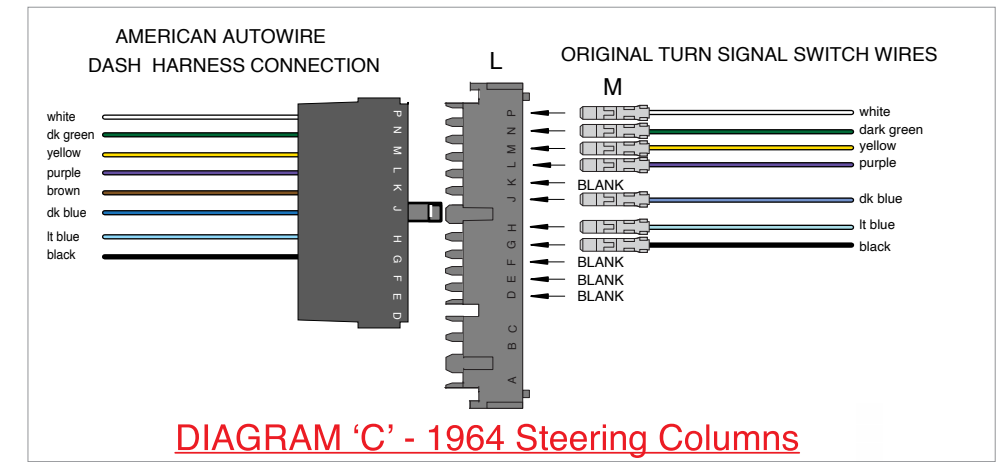
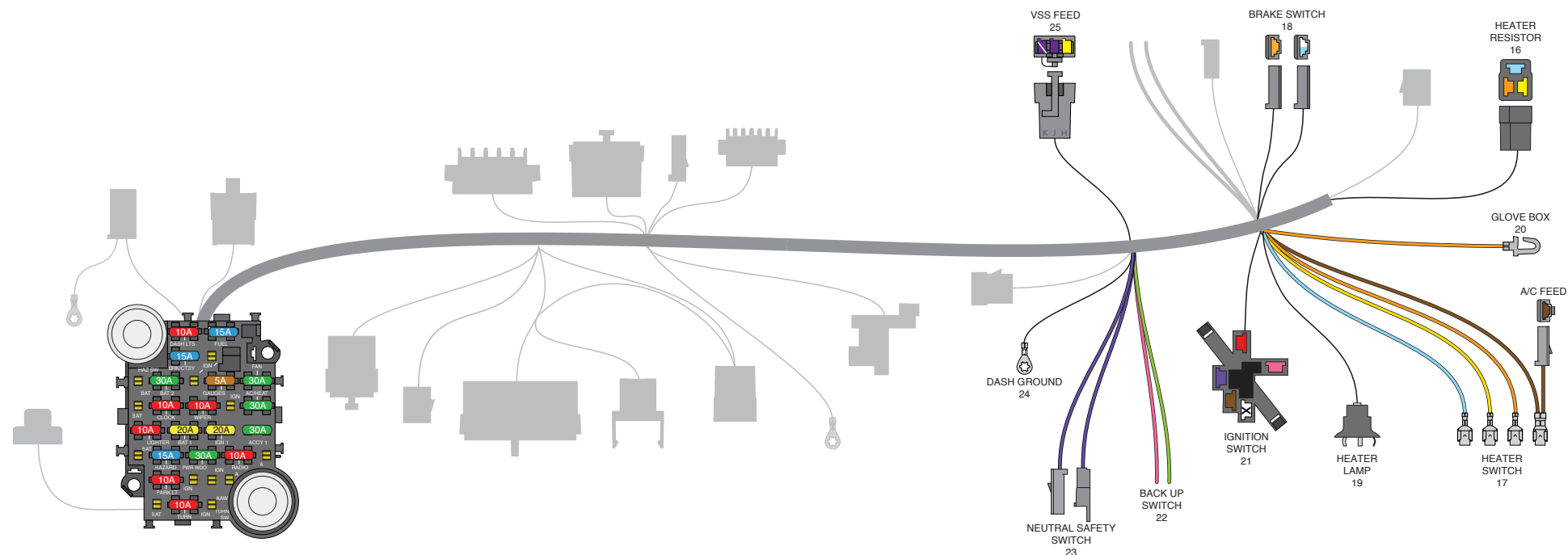

DIAGRAM 'C' - 1964 Steering Columns



www.americanautowire.com 856-933-0801





- | | |
|---------------------------|---|
| 16. HEATER RESISTOR | Plug this connector into the factory heater resistor located on top of the heater box of a non A/C car. |
| 17. HEATER SWITCH | Plug this connector into the factory heater switch. See Diagrams D and E for connector indexing.
Brown 12 volt accessory feed to heater / ac switch (if using aftermarket a/c, use the short brown wire as the accessory feed wire to a/c harness.)
Yellow Heater resistor
Lt Blue Heater resistor
Orange Heater resistor |
| 18. BRAKE SWITCH | Plug these connectors onto the factory brake switch.
Orange 12 volt feed 'in' to switch.
White 12 volt feed 'out' to steering column switch.
Lt Blue 12 volt feed 'out' to third brake light. |
| 19. HEATER LAMP | Gray Heater lamp |
| 20. GLOVE BOX LIGHT | Orange Connect to the original factory glove box lamp switch. If not using, just unplug and tape back. |
| 21. IGNITION SWITCH | Red 12 volt battery feed
Pink 12 volt ignition feed
Brown 12 volt accessory feed
Purple 12 volt starter feed |
| 22. BACK UP SWITCH | Connect these wires to the back up switch on the column or console shifter.
Pink 12 volt ignition feed 'in' to back up lamp switch
Lt Green 12 volt feed 'out' to back up lamps |
| 23. NEUTRAL SAFETY SWITCH | If using a column mounted automatic transmission, plug these wires into the NSS jumper harness in Diagram F at the right, then plug onto the neutral safety switch on the column. If using with console mounted automatic transmission, plug these wire into the NSS wires on the console harness. If using a manual transmission, plug these wires together.
Purple 12 volt feed 'in' to neutral safety switch.
Purple 12 volt feed 'out' to starter |
| 24. DASH GROUND | Black Connect to a good chassis ground. This must be at a different location than the ELECTRIC SPEEDO GROUND. |
| 25. VSS EXTENSION | These wires are for use with an aftermarket electric speedometer only. The VSS Lead Wires, 510730, bag V, will plug In here. Refer to that instruction sheet for wire functions and additional directions |

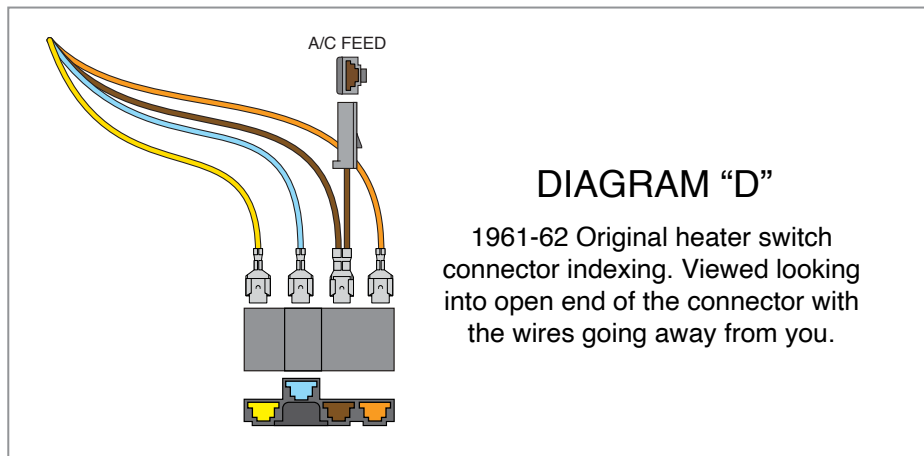

DIAGRAM "D"
 1961-62 Original heater switch connector indexing. Viewed looking into open end of the connector with the wires going away from you.

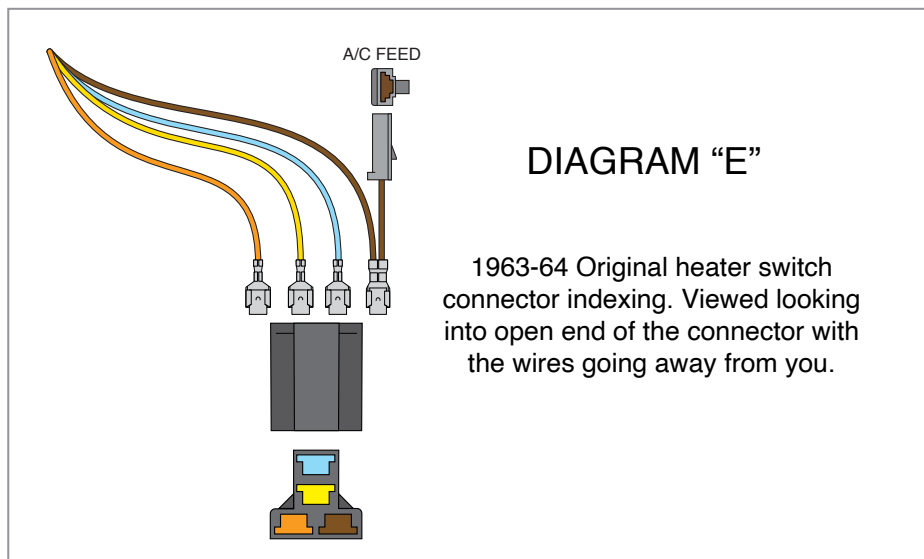

DIAGRAM "E"
 1963-64 Original heater switch connector indexing. Viewed looking into open end of the connector with the wires going away from you.

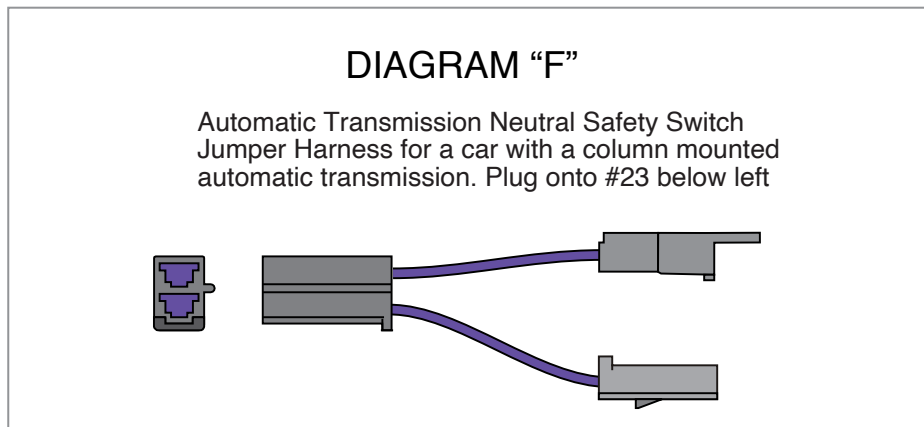

DIAGRAM "F"
 Automatic Transmission Neutral Safety Switch Jumper Harness for a car with a column mounted automatic transmission. Plug onto #23 below left



American Autowire

www.americanautowire.com 856-933-0801



Template for firewall modification for some Classic Update Kits

Classic Update Series kits are based on the 1968 and later GM bulkhead assembly which has a different mounting footprint than earlier bulkhead connectors. Therefore, it will be necessary to modify the firewall of the 1961-1964 Chevy Fullsize cars, the 1967-1968 Chevy and GMC trucks, and the 1969-1972 Chevy and GMC trucks to accept the 1968 and later design bulkhead. This enclosed template must be used for this purpose.

The white area should be cut out with a razor knife to define the area of material that needs to be removed from the existing bulkhead area. We suggest that this template be glued to stiff cardboard or a thin piece of plastic or be applied directly to the cleaned firewall on the inside of the car then proceed as follows:

1. Position the template against the firewall aligning the top and right hand edges with the top and right hand edges of the existing bulkhead hole.
2. Trace the opening area onto the existing bulkhead and cut out the area.
3. Drill the two .125 holes for the new bulkhead mounting screws.
4. Mount the fuse box assembly from the passenger compartment side and check the fit into the new bulkhead hole. It may be necessary the do some fine tuning on the hole size for an exact fit.
5. Screw in the new fuse box retaining screws to complete securing the new fuse box assembly to the firewall

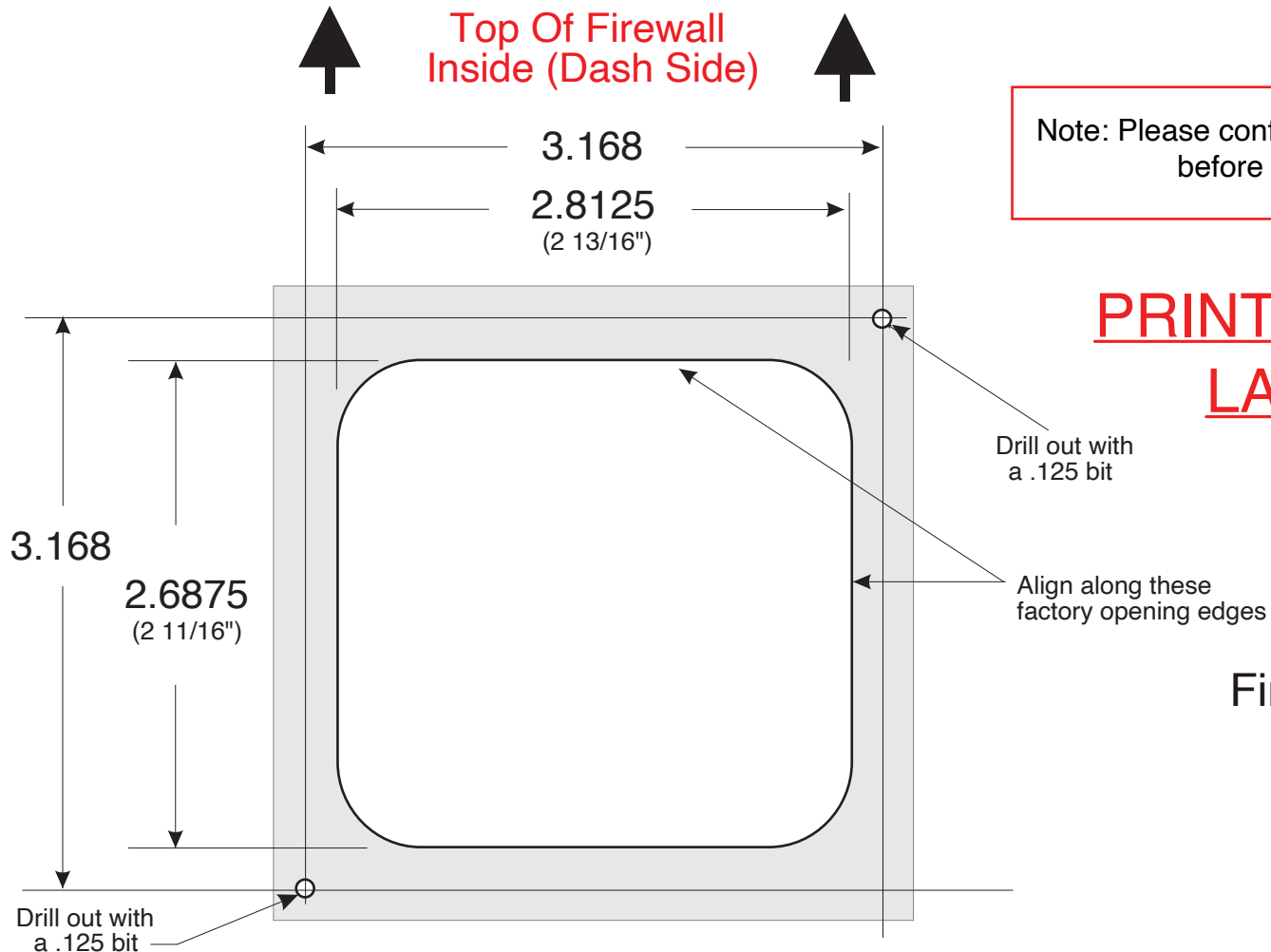

Note: Please confirm all measurements on this template before cutting or drilling any holes.

PRINT ON ADHESIVE LABEL SHEET



Firewall Modification Template

92968980

92968980 instructions Rev 4.0 9/18/2024

Classic Update Series

*** These are special instructions for connecting your wiring system to a stock instrument cluster. ***
 (Note: This kit does not support the use of a stock ammeter.)

REFER TO THE ATTACHED DIAGRAMS FOR YOUR APPLICATION YEAR. USE THE ENCLOSED PARTS AND INFORMATION BELOW FOR WIRE TERMINATION AND GAUGE CONNECTION.

NOTE: If you are using aftermarket gauges, follow the instructions from the after market gauge package included in this kit (92965220).

CONNECTOR A

TAN	Brake Warning Lamp	Install components shown on the following sheets, and plug into the brake light hole in cluster.
DK BLUE	Right Turn Indicator	Install components shown on the following sheets, and plug into the right turn indicator hole in the cluster.
LT BLUE	Left Turn Indicator	Install components shown on the following sheets, and plug into the left turn indicator hole in the cluster.
LT GREEN	Hi Beam Indicator Lamp	Install components shown on the following sheets, and plug into the high beam hole in cluster.
TAN	Fuel Gauge	Install components shown on the following sheets, and plug into the fuel gauge.
DK BLUE	Oil Gauge / Lamp	Install components shown on the following sheets, and plug into the oil gauge or lamp.
DK GREEN	Temp Gauge / Lamp	Install components shown on the following sheets, and plug into the temp gauge or lamp.
WHITE	Tach (loose wire)	This wire is used on factory gauge applications. Install components shown on the following sheets, and plug into the tachometer.
BROWN	Generator Lamp (loose wire)	This wire is used on warning lamp applications. This wire is stamped "ALT-IGN". Install components shown on the following sheets, and plug into the generator (alternator) lamp hole in cluster.

CONNECTOR B

PINK	12V ignition	Install components shown on the following sheets, and connect to gauges or warning lights requiring a 12V ignition feed.
LT GREEN	Temp Cold Lamp (loose wire)	Install components shown on the following sheets, and plug into the temp cold warning lamp. (Used on 62-64 models only).
GREY	Instrument Lamps	Install components shown on the following sheets, and plug into the instrument lamps.
BLACK	Ground	Connect to the back of the instrument cluster housing.

CONNECTOR C

This connector is used when using an aftermarket electronic speedometer. Follow the manufacturer's instructions when installing these wires. **The purple and yellow wires must remain twisted together!**

YELLOW	Speedo Ground	Connect to VSS "-" on speedometer.
PURPLE	Speedo Signal	Connect to VSS input on speedometer
PURPLE/WHITE	VSS power	Connect to VSS requiring a power
BLACK/WHITE	Speedo Ground	Connect to a unique chassis ground
PINK/White	Speedo power	Connect to speedometer power

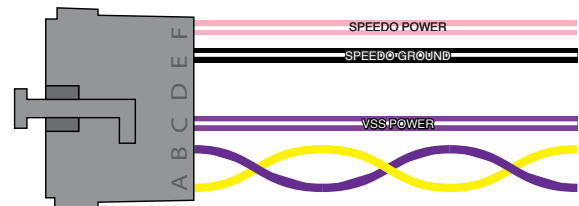

CLOCK EXTENSION

This wire assembly will plug into your factory dash mounted clock.

YELLOW	Clock 12V battery power	Connect this wire onto the power stud on the back of your clock and to the Dash harness.
--------	-------------------------	--



**American
Autowire**

www.americanautowire.com 856-933-0801

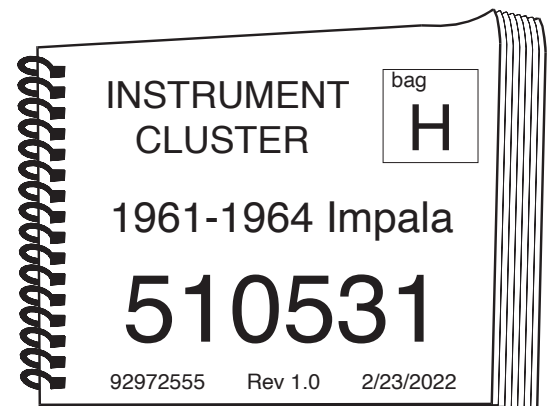

How to install lamp sockets and lamp socket terminals.

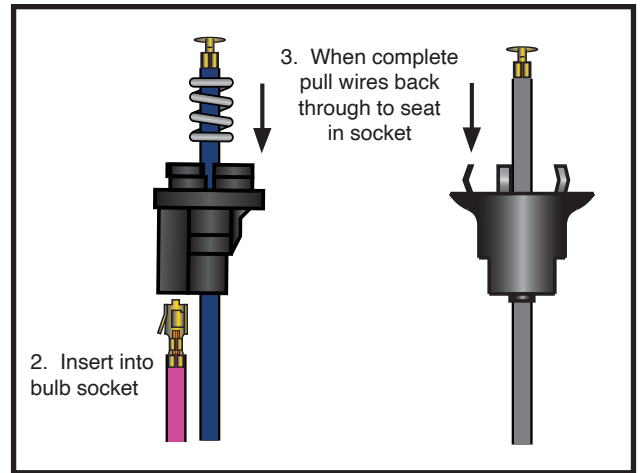
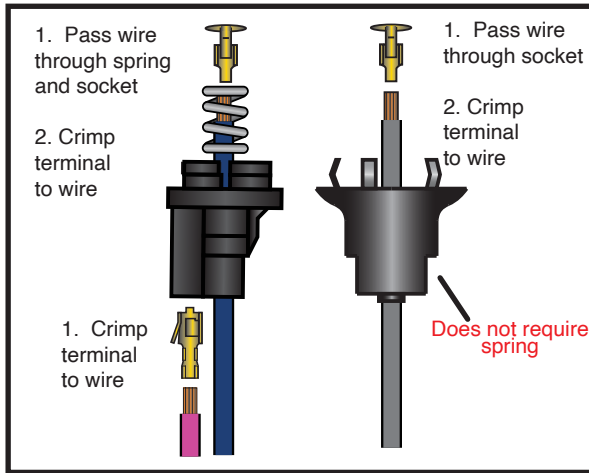

How to use the splice clip to join multiple wires.

Below is just an **EXAMPLE** of how to use the splice clip and shrink tubing; see your specific application on the following pages for actual splice information.

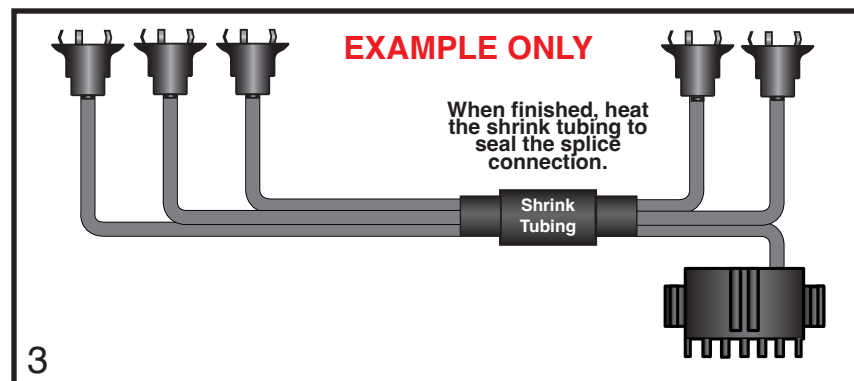
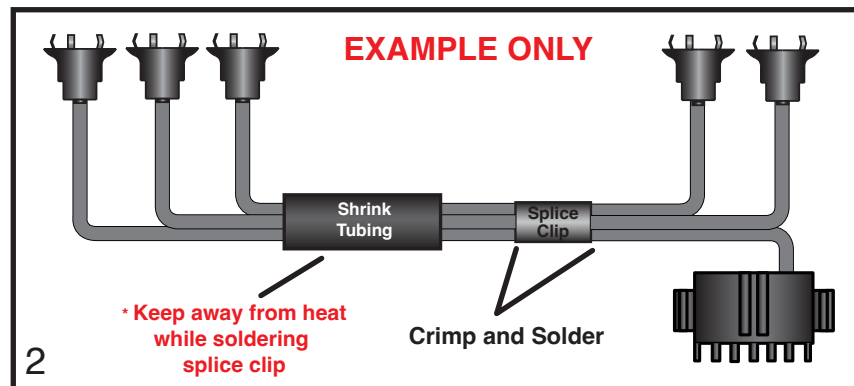
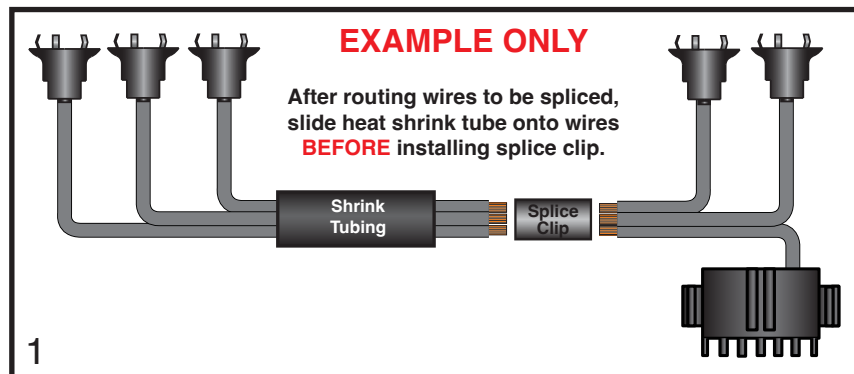

1961 Impala Cluster

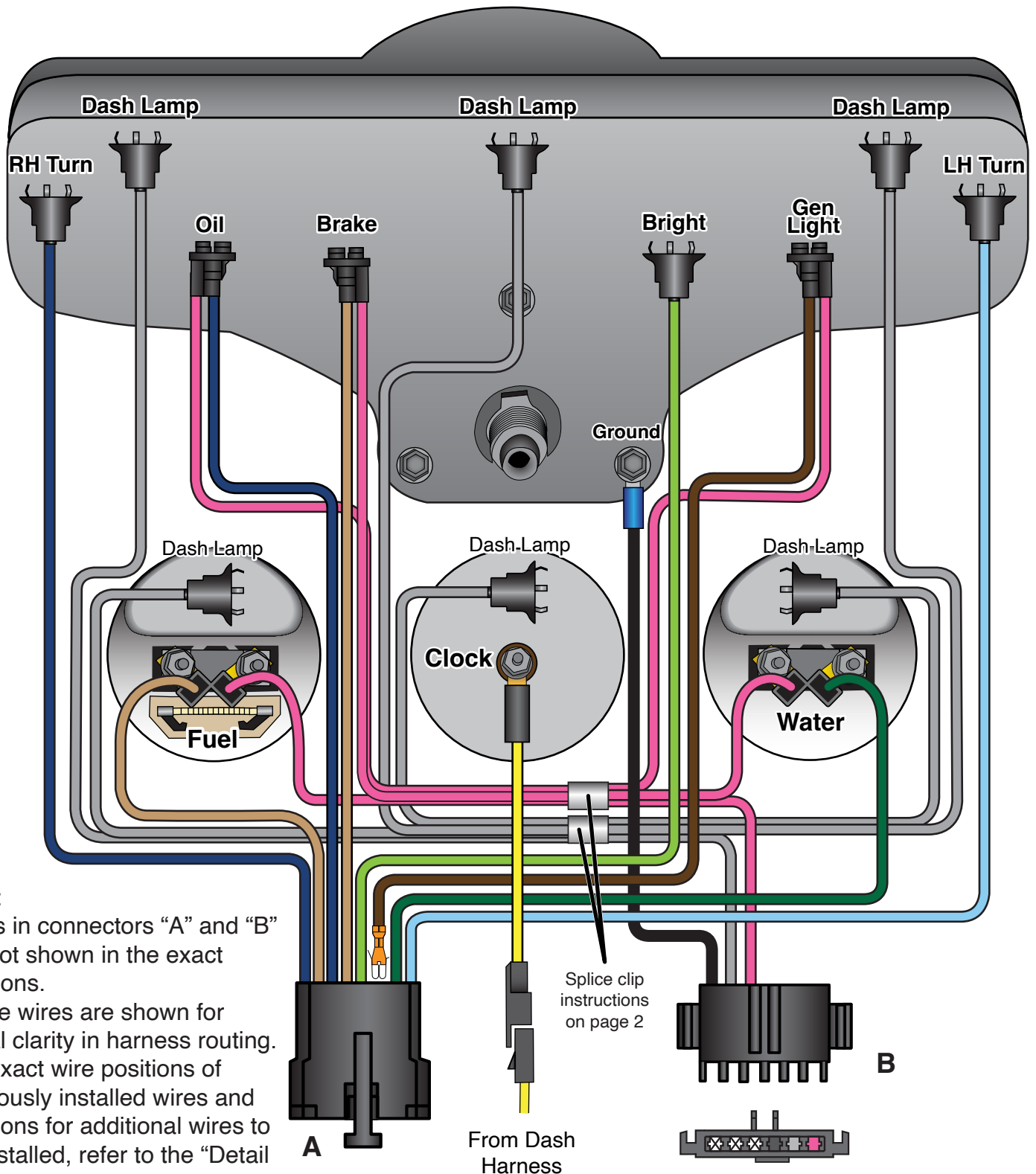

Note:
 Wires in connectors "A" and "B" are not shown in the exact positions. These wires are shown for visual clarity in harness routing. For exact wire positions of previously installed wires and positions for additional wires to be installed, refer to the "Detail View".

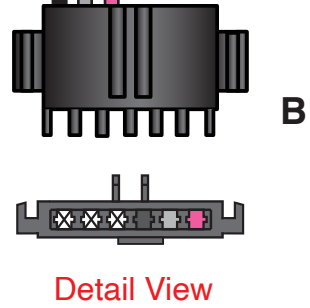
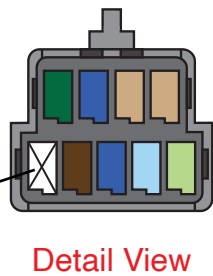

510531
 92972555
 Rev 1.0
 2/23/2022

1962 Impala Cluster

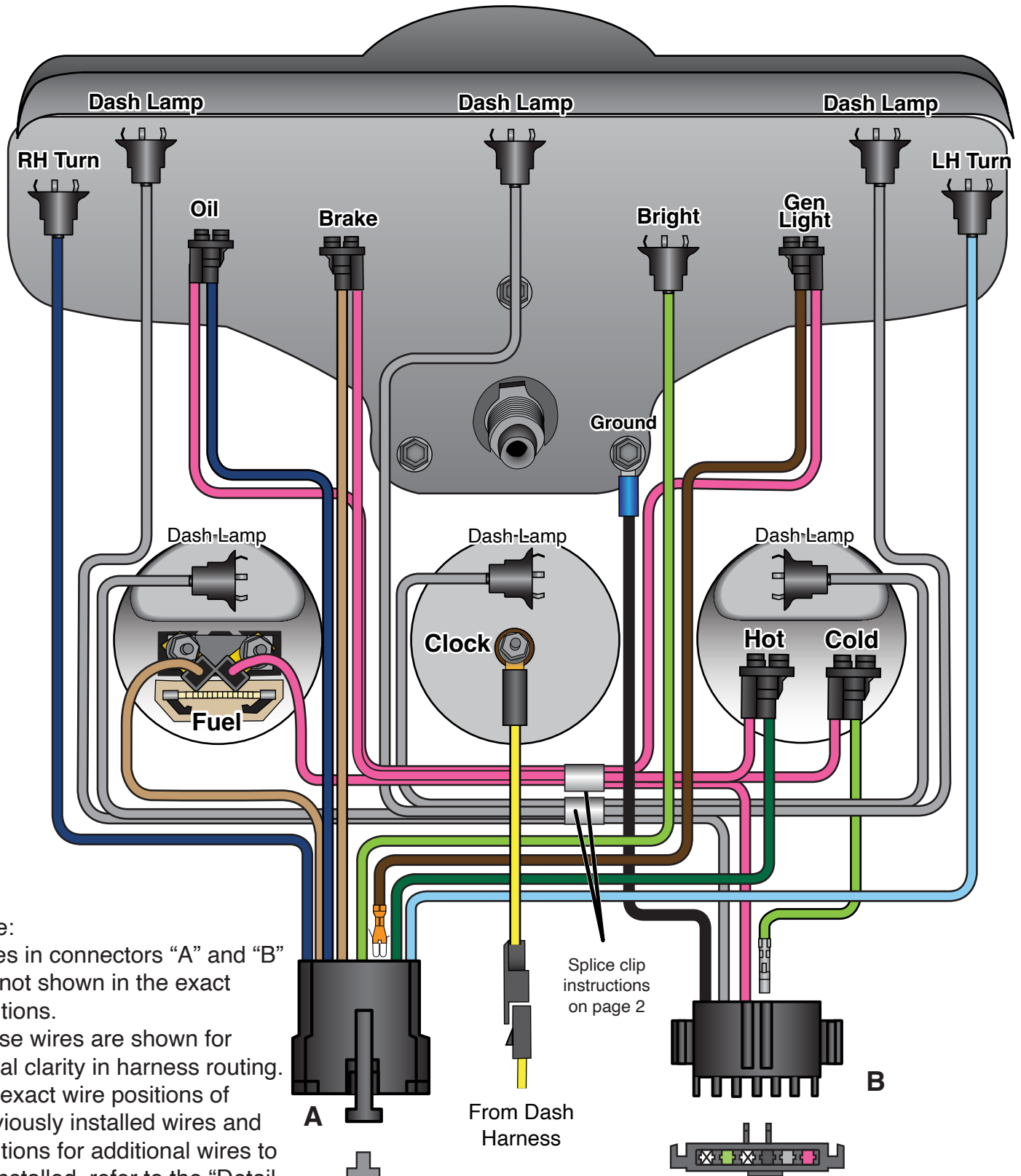

Note:
Wires in connectors "A" and "B" are not shown in the exact positions. These wires are shown for visual clarity in harness routing. For exact wire positions of previously installed wires and positions for additional wires to be installed, refer to the "Detail View".

Splice clip instructions on page 2

From Dash Harness

Install tach wire here, if used

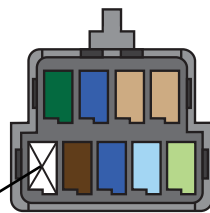

Detail View



Detail View



**American
Autowire**

www.americanautowire.com 856-933-0801

510531

92972555
Rev 1.0
2/23/2022

1963 Impala Cluster

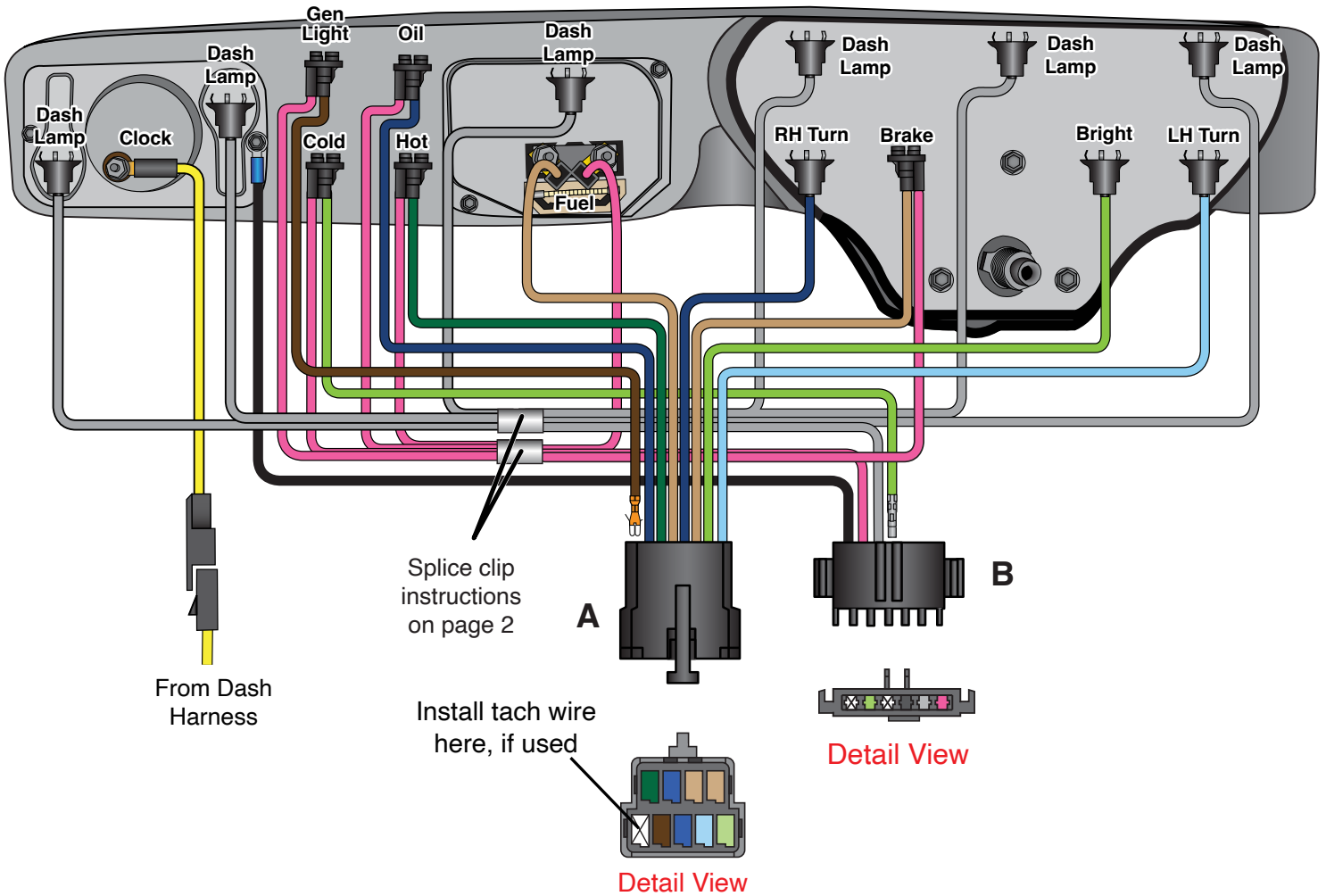

Note: Wires in connectors "A" and "B" are not shown in the exact positions. These wires are shown for visual clarity in harness routing.

For exact wire positions of previously installed wires and positions for additional wires to be installed, refer to the "Detail View"..



510531

92972555
Rev 1.0
2/23/2022

1964 Impala Cluster

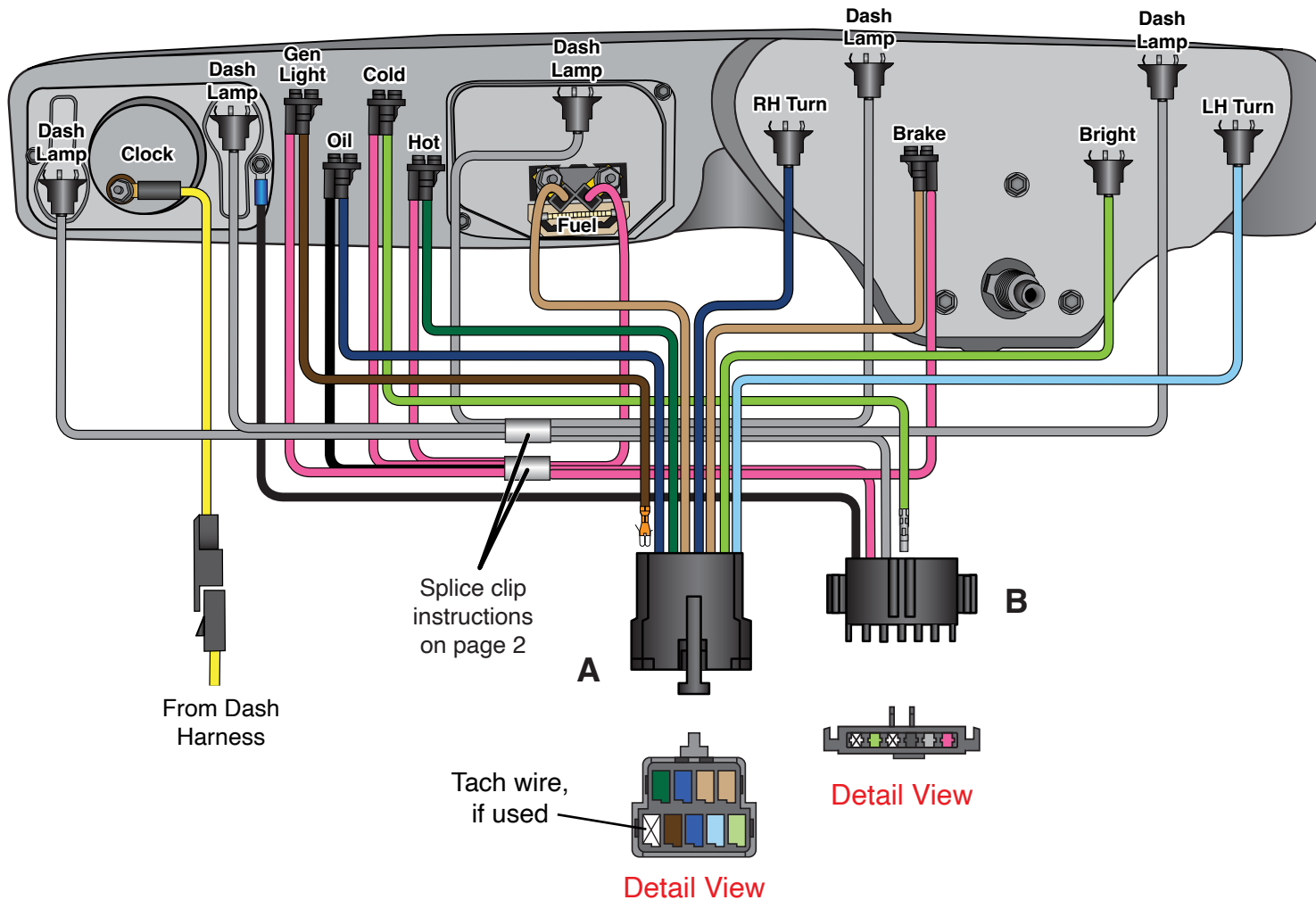

Note: Wires in connectors "A" and "B" are not shown in the exact positions. These wires are shown for visual clarity in harness routing.

For exact wire positions of previously installed wires and positions for additional wires to be installed, refer to the "Detail View"..



510531

92972555
Rev 1.0
2/23/2022

Classic Updarte Series

Gauge Cluster harness (aftermarket gauges) installation instructions:

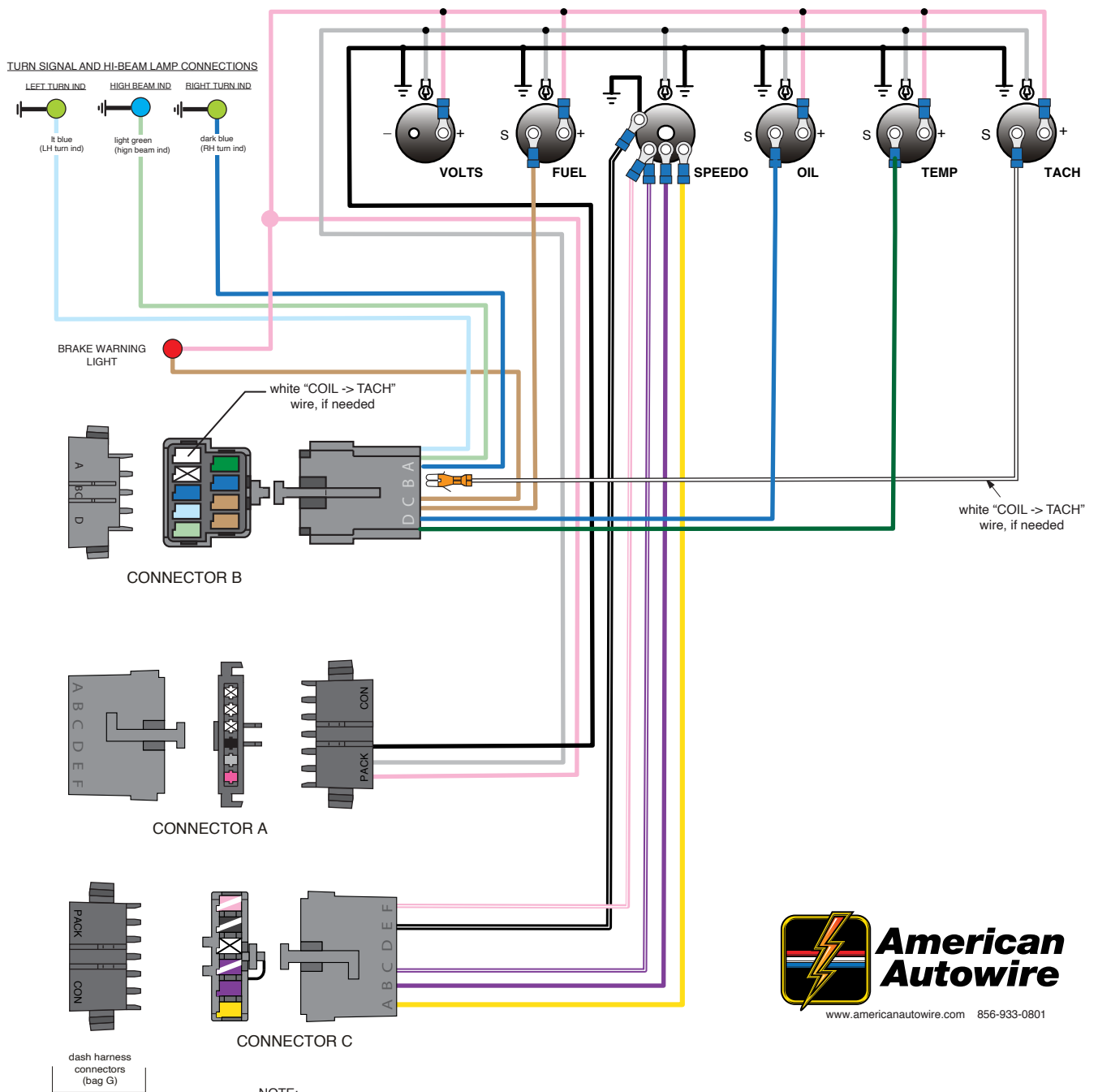

www.americanautowire.com 856-933-0801

NOTE:

These are general instructions for hooking up aftermarket gauges with an electric speedometer. Connector (C) will ONLY be used in the event that you are utilizing an aftermarket electric speedometer. If your car does NOT have an electric speedometer, then Connector C will NOT be used and should not be plugged onto your dash harness. It is best to consult the speedometer manufacturer's instructions if you have any questions.

Yellow VSS Ground Connect to VSS neg. "-" on speedometer.

Purple VSS Signal Connect to VSS input on speedometer.
NOTE: Twist the yellow and purple wires together for their entire length to prevent interference.

Black/White Speedo Ground Connect to ground on speedometer.

Pink/White Speedo Power Connect to 12v power on speedometer.
NOTE: This wire will double onto the same stud as the purple/white VSS power wire from above.

510531

92972555
Rev 1.0
2/23/2022



This page intentionally left blank.

510531

92972555
Rev 1.0
2/23/2022

Electric Speedo VSS extension connection:

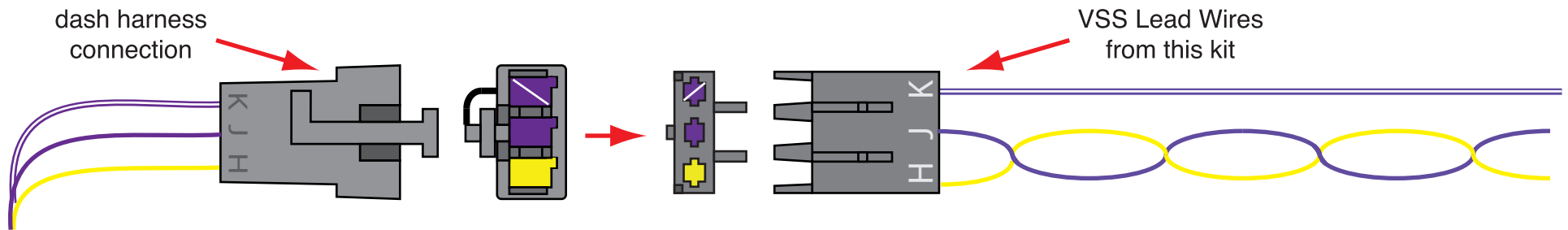

If you are using an aftermarket electric speedometer in your vehicle, you will need to connect the vehicle speed sensor (VSS) Lead Wires from this kit to the dash side connection of your dash harness. The yellow and solid purple wires must remain twisted together as shown above. These three wires will need to pass through the firewall or floor of your vehicle down to the vehicle speed sensor unit in the transmission. Generally, the solid purple wire connects to the “signal” lead, the yellow wire connects to the “ground” lead, and the purple/white stripe wire connects to the “12 volt power” lead on the vehicle speed sensor assembly. However, you should consult the directions that came with your gauges, and connect your vehicle speed sensor per the manufacturer’s instructions.



www.americanautowire.com 856-933-0801

VSS LEAD WIRES
Various Applications
Classic Update Series

510730

92972371 Rev 0.0 4/9/2019

bag
V

Classic Update Series

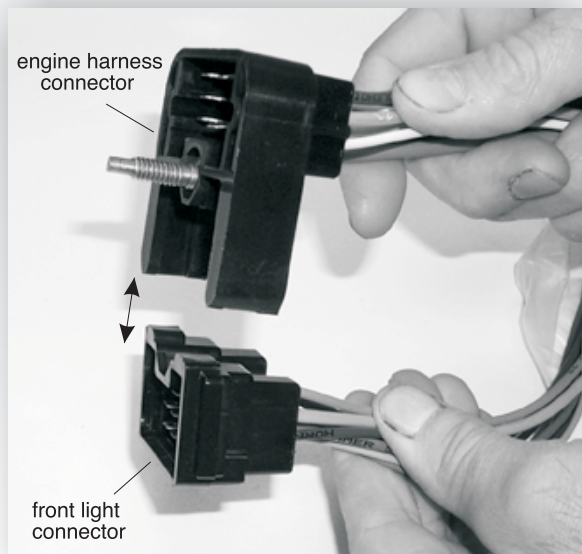

The bulkhead connector from this Engine kit must snap into the mating engine connector (bag L), as shown. After snapping together, then bolt the assembly into the dash harness firewall connector using the attached bolt.

Look!



American Autowire also sells factory OEM style harness wrap. this is the same stuff used on original Camaro harnesses! If you want that OEM look with your Classic Update wiring system, then give us a call and order p/n R0067108 !



**American
Autowire**

www.americanautowire.com 856-933-0801

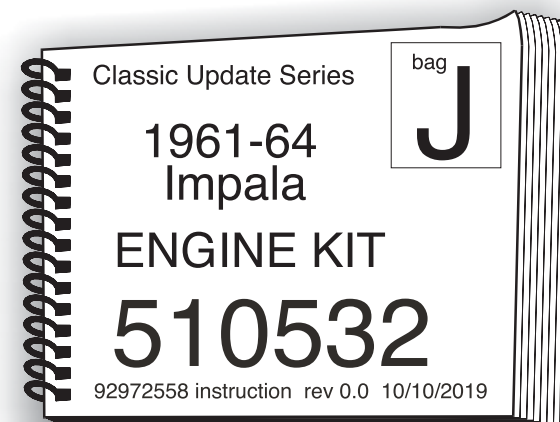

Terminals used in this installation.

This kit contains loose piece terminals and connectors necessary to complete a connection to a specific component. Each connection on the instruction sheet identifies specific parts by a letter code that corresponds to the letter code on a part picture identified below. The parts below are shown in actual size to help in identification. This kit will only contain those parts required for the connections in the specific sub-kit you are working on. Just match the part to the picture below to identify the part letter code you will see on the instruction sheet for the sub-kit harness you are working on. We have supplied additional terminals in the event that extra terminals are necessary.

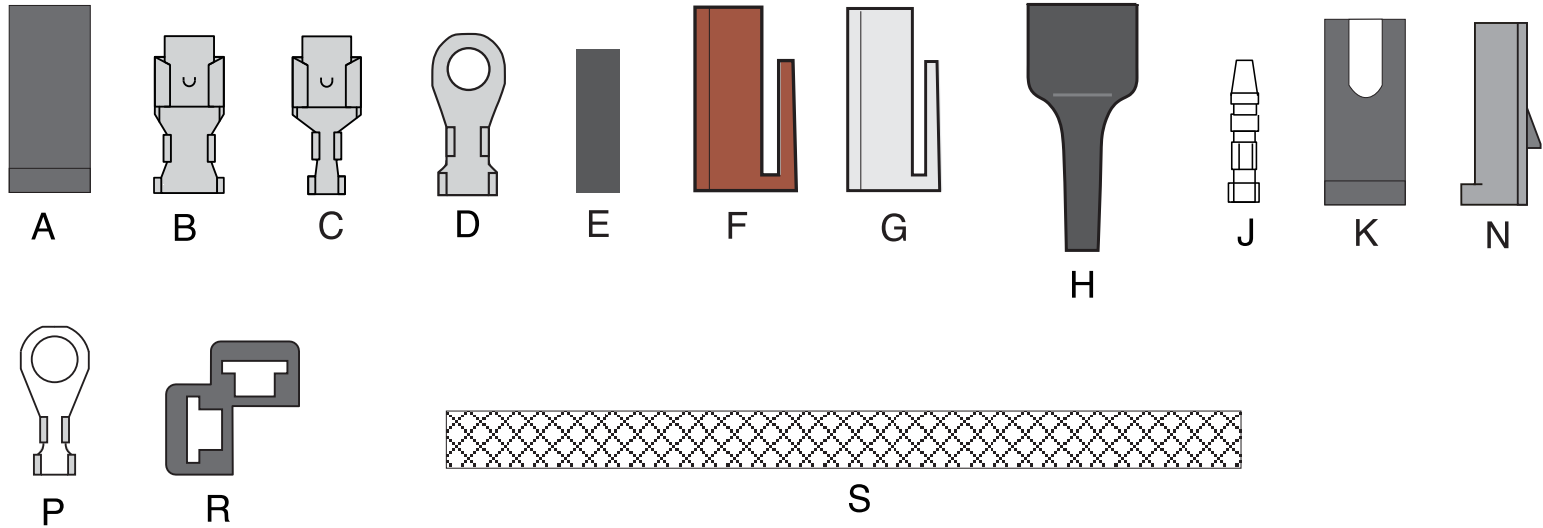

TEMPORARILY, PLUG THE MAIN BULKHEAD CONNECTOR FROM THIS KIT INTO THE MATING CONNECTOR ON THE DASH BULKHEAD CONNECTOR (LOCATED UNDER THE MASTER CYLINDER) Note: This will be unbolted to install the front light harness later.

RED	12 V BATTERY	Route this wire to the Megafuse and cut to length. Use ring terminal, shrink tubing from 510476 kit. Connect as shown on sheet 3.
PURPLE	STARTER SOLENOID	Route to the starter solenoid and cut to length. Install rubber sleeve E and ring terminal D. Connect to the "S" terminal on the solenoid.
PINK	12 V IGNITION	If using an HEI distributor or after-market ignition system which requires a 12 volt feed, route the PINK wire to the coil and trim to length. Install terminal C and connector G, and plug into the distributor cap BAT location.
YELLOW	STARTER SOLENOID-R	If using a points type ignition system which requires reduced voltage, route the PINK wire to the ignition feed side of a ballast resistor (not included). Connect the loose piece YELLOW (STARTER SOLENOID-R) wire to the R terminal on the starter and connect the other end to the coil side of the ballast resistor (not included). Connect a piece of left over PINK wire to the coil side of the ballast resistor and route to the distributor coil positive (+) side. Connect the distributor input lead wire to the coil negative (-) side.
RED	(no printing) (heavy gauge)	Use the 6ga red wire, boot, and ring terminal from the 510476 kit, route from alternator to the Megafuse and cut to length. Connect as shown on sheet 3.
RED	(no printing) (small gauge)	Send the ring terminal end of this wire through boot L (as shown on sheet 3) and connect to the battery stud on the alternator. Do not plug the connector into the alternator yet. The brown exciter wire will still need to be added to this connector before it is plugged into the alternator.
BROWN	ALTERNATOR IGN	Route this wire to the alternator and cut to length. Install terminal C and plug into the regulator connector. The regulator connector can now be plugged into the alternator.
WHITE	WIPER FEED	This is the 12 volt feed wire for the wipers. Plug this wire into the bulkhead connector in the location shown on sheet 3. Route this wire to the wiper motor, trim to length, install terminal C and plug into connector A.
TAN	ELECTRIC CHOKE	If you are using a carburetor with an electric choke, connect this wire to the electric choke connection. If you are not using an electric choke remove this wire from the engine bulkhead connector.
ORANGE	HEAT / AIR	If using stock or after-market air conditioning, this wire will not be used. If using a stock heater only system, plug this wire into the bulkhead connector in the location shown on sheet 2. Route this wire to the heater blower and cut to length, install terminal C and connector K (1961, 1962, 1964) or slide through boot H, install terminal J (1963) and plug into the blower unit.
WHITE	COIL-TACH	Route this wire to the coil and trim to length. If using an HEI distributor, terminal B and connector F are included for connection to the TACH location. If using a conventional coil, terminal P is included for connection to the negative (-) side of the coil. If you are not using a tachometer, remove this wire from the bulkhead connector.
DARK BLUE	OIL PRESSURE SENDER	Connect this wire to the oil pressure sending unit using terminal P or terminal C together with connector A.
DARK GREEN	WATER TEMP SENDER	Connect this wire to the temperature sending unit using terminal P or terminal C and connector A (depending on your sending unit).
LIGHT GREEN	no printing	NOTE: This wire will only be used when using your stock HOT/COLD dash indicator warning lamp on the 1962-1964 models. Plug this loose wire (for cold lamp) into the main connector as shown on sheet 3 (1962-64 applications only). Route the other end through loom S, install terminal C and plug into connector R as shown on sheet 3.

Once the main connector has had all of it's wires plugged in, the connector cavities should be sealed with dielectric grease on the terminals. Also, to assure a moisture resistant seal, silicone can be applied to seal the outside of the connector.

ENGINE KIT
510532
92972558 instruction rev 0.0 10/10/2019

Classic Update Series

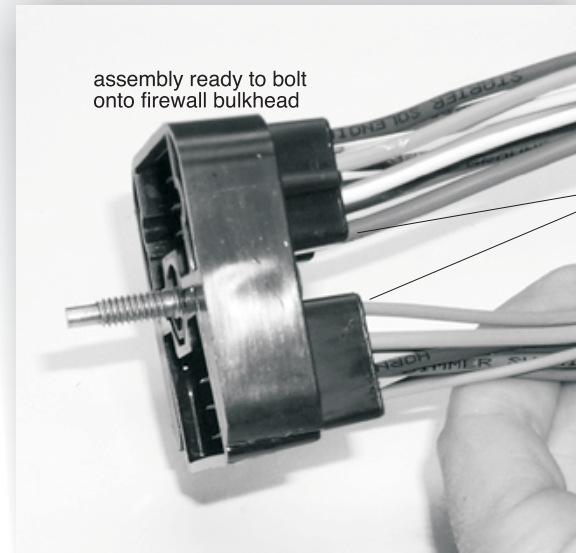
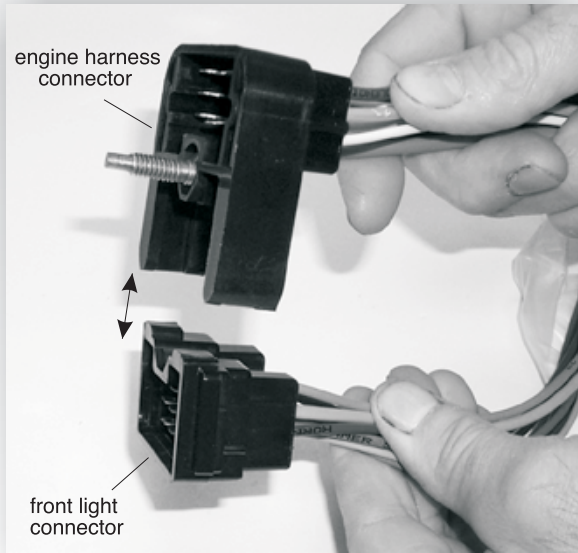

apply silicone sealant to back side of connector after installing terminals

The bulkhead connector from this front light kit must snap into the mating engine connector (bag J), as shown. After snapping together, then bolt the assembly into the dash harness firewall connector using the attached bolt.

Look!



**American
Autowire**

www.americanautowire.com

American Autowire also sells factory OEM style harness wrap. this is the same tape used on original harnesses! If you want that OEM look with your Classic Update wiring system, then give us a call and order p/n R0067108 !



Terminals used in this installation.

This kit contains loose piece terminals and connectors necessary to complete a connection to a specific component. Each connection on the instruction sheet identifies specific parts by a letter code that corresponds to the letter code on a part picture identified below. The parts below are shown in actual size to help in identification. This kit will only contain those parts required for the connections in the specific sub-kit you are working on. Just match the part to the picture below to identify the part letter code you will see on the instruction sheet for the sub-kit harness you are working on. We have supplied additional terminals in the event that extra terminals are necessary.

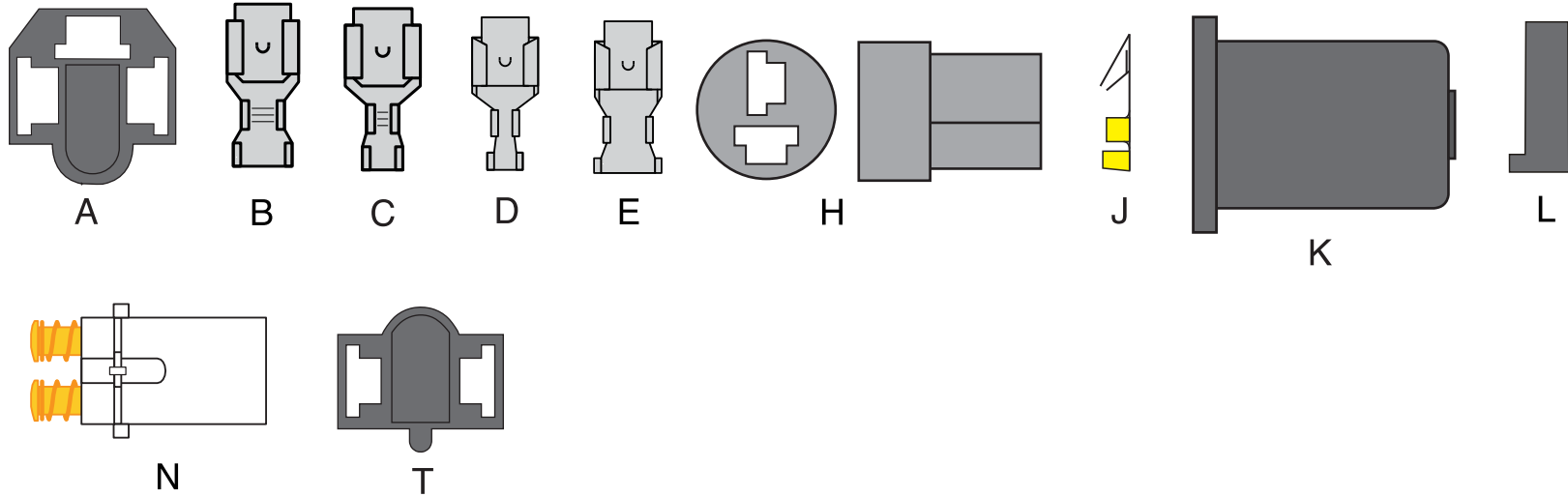

Classic Update Series

FRONT LIGHT KIT

510533

92972561 instruction rev 0.0 9/25/2019

1961-63 IMPALA

Connect the bulkhead connector from this kit onto the bulkhead connector from the engine kit (bag J), and bolt to the firewall dash bulkhead. After all wires are installed from this kit, the main connector should have die-electric grease applied to the terminals and silicone sealer applied to the outside of the connectors as a moisture seal.

LIGHT BLUE	LEFT FRONT TURN	Route this wire to the Left hand turn signal lamp, slide wire through boot K, install terminal J and plug into lamp socket N as shown on sheet 3.
DARK BLUE	RIGHT FRONT TURN	Route this wire to the Right hand turn signal lamp, slide wire through boot K, install terminal J and plug into lamp socket N as shown on sheet 3.
BROWN	PARK LIGHTS	Route one of the brown wires to the Left hand turn signal lamp, slide wire through boot K, install terminal J and plug into lamp socket N as shown on sheet 3. Route the other brown wire to the Right hand turn signal lamp, slide wire through boot K, install terminal J and plug into lamp socket N as shown on sheet 3.
TAN	HEADLIGHT LOW BEAM	Route this wire to the driver side outer headlight and trim to length. Double this wire with the cutoff portion, and install terminal B. Plug this terminal into connector A in the location shown on sheet 3. Route the remaining portion of this TAN wire to the passenger side outer headlight and trim to length. Install terminal C and plug into connector A as shown on sheet 3.
LIGHT GREEN	HEADLIGHT HIGH BEAM	Route this wire to the driver side outer headlight and trim to length. Double this wire with the cutoff portion, and install terminal B. Plug this terminal into connector A, make a short jumper over to the driver side inner headlight, cut to length, double it with the cutoff portion, install terminal B, and plug it into connector T in the location shown on sheet 3. Route the remaining portion of this LIGHT GREEN wire to the passenger side inner headlight and trim to length. Double this wire with the cutoff portion, install terminal B and plug into connector T as shown. Make a short jumper over to the passenger side outer headlight, cut to length, double it with the cutoff portion, install terminal C, and plug it into connector A in the location shown on sheet 3.
BLACK	GROUND	Attach the ring terminal to a good chassis ground then route this wire to the driver side outer headlight, trim to length, double this wire with the cutoff portion, install terminal B and plug this terminal into connector A. Route the remaining portion of this BLACK wire over to the driver side inner headlight, cut to length, install terminal C and plug it into connector T in the location shown on sheet 3. Repeat this process for the passenger side.
DARK GREEN	HORN	Route to horns and install terminals D & E, as shown on sheet 3. Plug into connectors L.
ORANGE	ELECTRIC FAN	Route to the electric fan and connect as per the manufacturer's instructions. NOTE: We recommend that this wire be used as the trigger wire for the electric fan relay.
TAN	BRAKE LIGHT SWITCH	If your car is equipped with a brake warning system, plug this wire into the main connector as shown on sheet and splice the other end onto your brake sender switch connection. NOTE: (brake switch connection not included in kit)

Classic Update Series

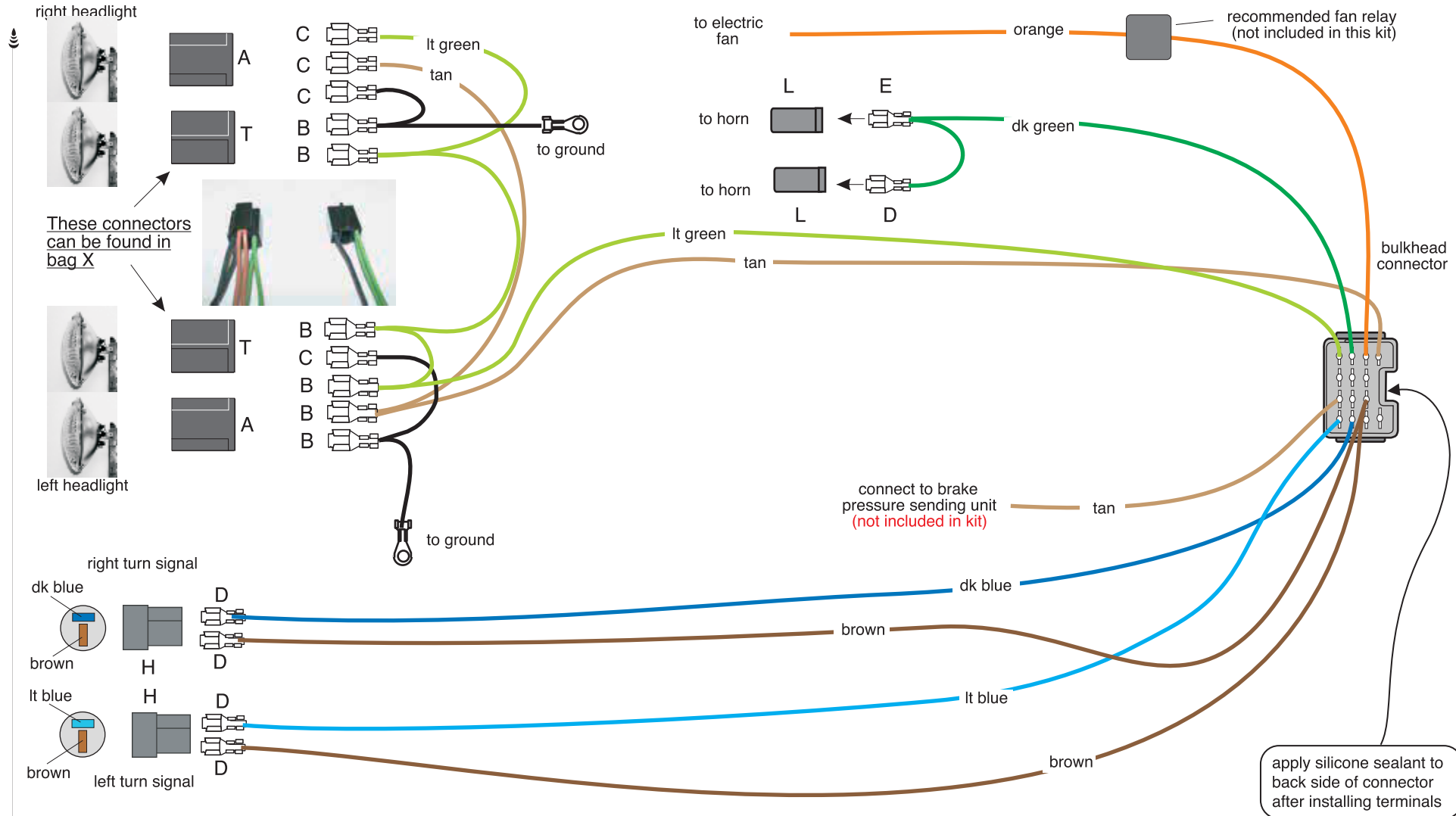

1964 Impala Front Light

1964 IMPALA

Connect the bulkhead connector from this kit onto the bulkhead connector from the engine kit (bag J), and bolt to the firewall dash bulkhead. After all wires are installed from this kit, the main connector should have die-electric grease applied to the terminals and silicone sealer applied to the outside of the connectors as a moisture seal.

LIGHT BLUE	LEFT FRONT TURN	Route this wire to the Left hand turn signal lamp, install terminal D and plug into connector H as shown on sheet 5.
DARK BLUE	RIGHT FRONT TURN	Route this wire to the Right hand turn signal lamp, install terminal D and plug into connector H as shown on sheet 5.
BROWN	PARK LIGHTS	Route one of the brown wires to the Left hand turn signal lamp, install terminal D and plug into connector H as shown on sheet 5. Route the other brown wire to the Right hand turn signal lamp, install terminal D and plug into connector H as shown on sheet 5.
TAN	HEADLIGHT LOW BEAM	Route this wire to the driver side outer headlight and trim to length. Double this wire with the cutoff portion, and install terminal B. Plug this terminal into connector A, in the location shown on sheet 4. Route the remaining portion of this TAN wire to the passenger side outer headlight and trim to length. Install terminal C and plug into connector A as shown on sheet 5.
LIGHT GREEN	HEADLIGHT HIGH BEAM	Route this wire to the driver side outer headlight and trim to length. Double this wire with the cutoff portion, and install terminal B. Plug this terminal into connector A, make a short jumper over to the driver side inner headlight, cut to length, double it with the cutoff portion, install terminal B, and plug it into connector T in the location shown on sheet 5. Route the remaining portion of this LIGHT GREEN wire to the passenger side inner headlight and trim to length. Double this wire with the cutoff portion, install terminal B and plug into connector T as shown. Make a short jumper over to the passenger side outer headlight, cut to length, double it with the cutoff portion, install terminal C, and plug into connector A in the location shown on sheet 5.
BLACK	GROUND	Attach the ring terminal to a good chassis ground then route this wire to the driver side outer headlight, trim to length, double this wire with the cutoff portion, install terminal B and plug this terminal into connector A. Route the remaining portion of this BLACK wire over to the driver side inner headlight, cut to length, install terminal C and plug it into connector T in the location shown on sheet 3. Repeat this process for the passenger side
DARK GREEN	HORN	Route to horns and install terminals D & E, as shown on sheet 5, Plug into connectors L.
ORANGE	ELECTRIC FAN	Route to the electric fan and connect as per the manufacturer's instructions. NOTE: We recommend that this wire be used as the trigger wire for the electric fan relay.
TAN	BRAKE LIGHT SWITCH	If your car is equipped with a brake warning system, plug this wire into the main connector as shown on sheet 5 and splice the other end onto your brake sender switch connection NOTE: (brake switch connection not included in kit).

Classic Update Series

Route these wires from the driver-side kick panel to the b-pillar, rear package tray, area.

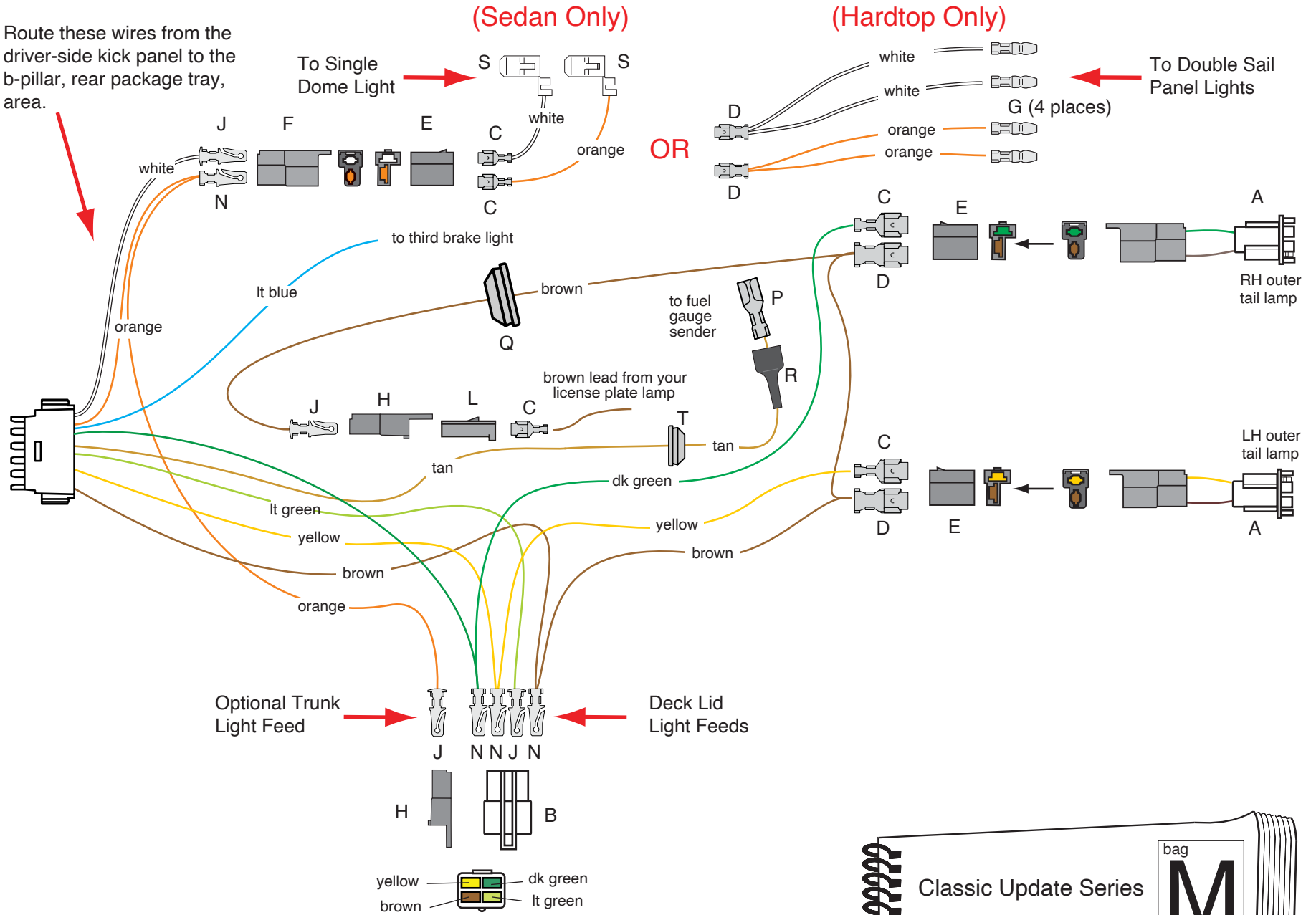

USE THIS SHEET FOR ALL
61-64 Impalas

NOTE: LH trunk hinge area.
Your deck lid harness and
deck lid lamp assembly will
plug in here.













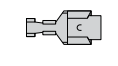
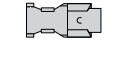

Classic Update Series **M**

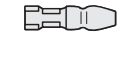
REAR BODY KIT

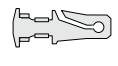
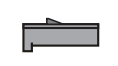
510761

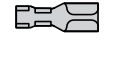
92972681 instruction rev 1.0 06/01/2023

USE THIS SHEET FOR A 61-64 IMPALA

A		Connect the main connector to the mating connector on the dash harness (510530), bag G. Route this harness along the door sill, and into trunk area.
LIGHT BLUE		Third Brake Light Connect to the third brake lamp, if equipped.
B		TAN Fuel Tank Lead Route this wire to the fuel sending unit at the rear of the car, measure to the proper length going thru the access hole in trunk floor and cut to length. Slide grommet T onto the wire in the direction shown on sheet 1, slide boot R onto the wire, strip the end and crimp terminal P onto wire. Once terminal P is secured to the wire, pull boot R down over terminal P and install onto sending unit.
C		
D		BROWN Rear Running Lamps Route this wire to the left hand trunk hinge area and trim to length. Double this wire with the cut off portion, install terminal N and plug into connector B as shown on page 1. Route the loose end to the LH tail light area and trim to length. Double this wire with the cut off portion, install terminal D and plug into connector E as shown on page 1.
E		Route the loose end to the right side tail light area and trim to length. Double this wire with the cut off portion, install terminal D and plug into connector E as shown on page 1. Route the loose end to the license plate lamp area going through the access hole in the trunk floor, and trim to length. Slide grommet Q onto the wire in the direction shown on sheet 1. Install terminal J and plug into connector H as shown on page 1. Plug your license lamp assembly into connector H as shown on page 1. If your original license lamp assembly connection is damaged, we have provided new terminal and connector C and L for your convenience.
F		Route the loose end to the license plate lamp area going through the access hole in the trunk floor, and trim to length. Slide grommet Q onto the wire in the direction shown on sheet 1. Install terminal J and plug into connector H as shown on page 1. Plug your license lamp assembly into connector H as shown on page 1. If your original license lamp assembly connection is damaged, we have provided new terminal and connector C and L for your convenience. NOTE: We have provided assembled tail lamp extension pigtails A (yellow/brown LH and dk green/brown RH) as shown on page 1. DO NOT plug connectors E into these pigtails yet!
G		
H		YELLOW LH Stop / Tail Route this wire to the left hand trunk hinge area and trim to length. Double this wire with the cut off portion, install terminal N and plug into connector B as shown on page 1. Route the loose end to the LH tail light area and trim to length. Install terminal C and plug into the open cavity of connector E of the LH tail lamp pigtail A (yellow/brown) as shown on page 1. Plug connector E into LH tail lamp extension pigtail A (yellow/brown).
J		
L		DK GREEN RH Stop / Tail Route this wire to the left hand trunk hinge area and trim to length. Double this wire with the cut off portion, install terminal N and plug into connector B as shown on page 1. Route the loose end to the RH tail light area and trim to length. Install terminal C and plug into the open cavity of connector E of the RH tail lamp pigtail A (dk green/brown) as shown on page 1. Plug connector E into RH tail lamp extension pigtail A (dk green/brown)
N		LIGHT GREEN Back Up Feed Route this wire to the left hand trunk hinge area and trim to length. Install terminal J and plug into connector B as shown on page 1.
P		WHITE Courtesy Ground If you are using a dome lamp, at the driver's side kick panel area, trim this wire to a length of 10 inches, install terminal J, and plug into connector F as shown on page 1. Use the remaining white wire to create a dome lamp harness using terminals C and S and connector E for sedan models, or terminals D and G for hardtop models as shown on page 1. Be sure to maintain color continuity between connectors E and F.
Q		
R		ORANGE Courtesy Feed If you are using a dome lamp, at the driver's side kick panel area, trim this wire to a length of 10 inches. Double this wire with the cut off portion using terminal N, and plug into connector F containing the white wire as shown on page 1. Route the loose end of this wire to the rear trunk hinge area of the trunk, install terminal J and connector H creating your trunk lamp feed. Use the remaining orange wire to create a dome lamp harness using terminals C and S and connector E for sedan models, or terminals D and G for hardtop models as shown on page 1. Be sure to maintain color continuity between connectors E and F. (Note: your original factory dome lamp harness will also plug into connector F if you are not replacing the headliner at this time.)
S		
T		



Deck Lid Harness

This harness routes just as your original factory harness did.

- The orange wire is a constant, fused 12 volt battery feed that may be used to supply power to a trunk lamp or to select programmable LED light controllers. This wire gets power from the "BRK/CTSY" fuse.
- The light green wires are for the back up lamps.
- The brown, yellow and dark green wires are for the tail, stop and turn lamps.
- The 4-position connector (A) with light green, brown, yellow, and dark green wires and the single-position connector (B) with the orange wire will plug into the rear body harness at the trunk hinge area inside of your trunk lid.

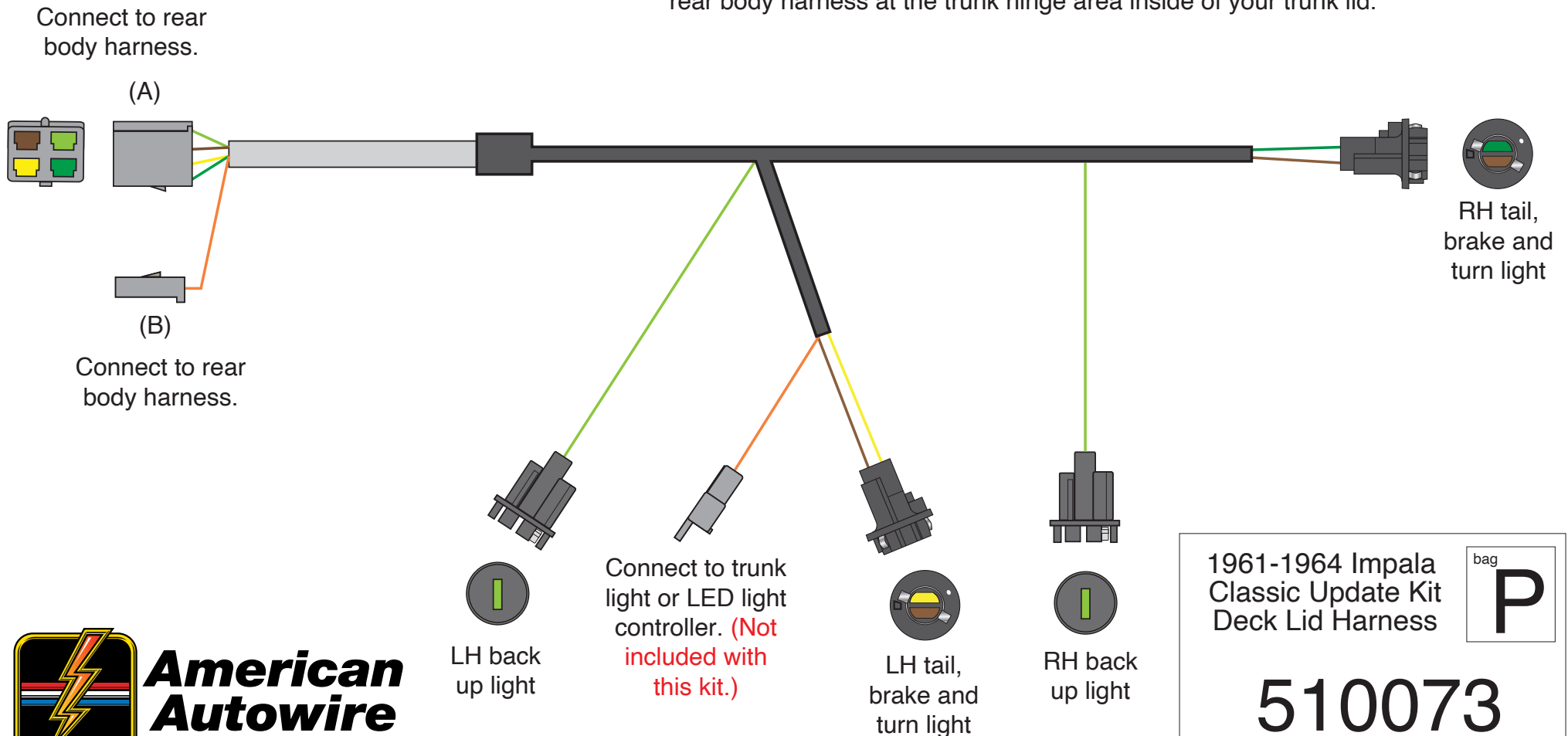

www.americanautowire.com 856-933-0801

1961-1964 Impala
Classic Update Kit
Deck Lid Harness

bag
P

510073

92968974 instruction rev 2.0 5/12/2023

Most switches supplied with Classic Update and Universal Kits ship with the shaft pre-installed. In many instances, the switch can be installed without removing the shaft, but in some cases the switch shaft may need to be trimmed to fit your specific dash. In this situation, reference Trim to Fit instructions on the back of this page for details.

To install your new headlight switch:

1. Install the switch from behind the dash, and align the switch body with the mounting hole. The switch body has an alignment tab that must line up with the notch in the dashboard mounting hole.

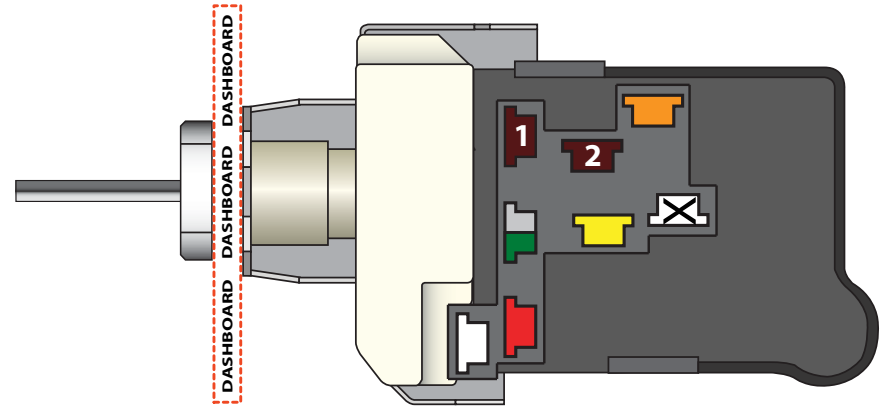
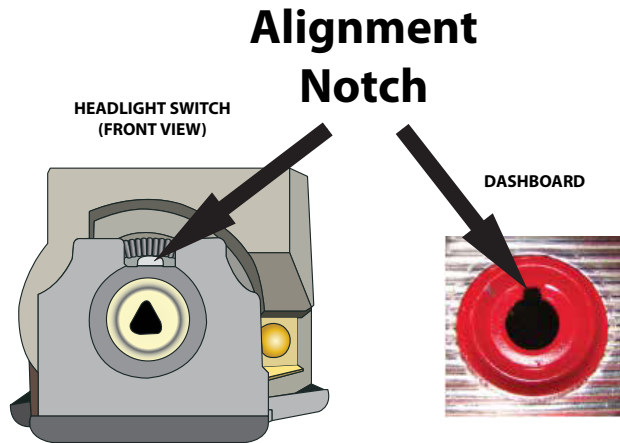

1	Parking Lights - Stay on with headlights
2	Tail Lights - On in the park and headlight positions
	Fused Battery Feed - For park, tail and dash lamps
	Headlight Feed - Power to the headlight dimmer switch
	12V Battery Feed - Unfused power to the switch for headlights
	Courtesy Ground - Ground feed to the dome and courtesy lights
	Part-time Parking Lights - Turns off when the headlights are on (Not supported by all kits)
	Dash Lights - Output to the dash light fuse or lights

2. Install the switch mounting nut and tighten.
3. Gently press shaft into switch until it stops, then press firmly until it "clicks." Pull shaft back out to confirm it is seated correctly. The shaft should be locked into place inside switch.
4. If the shaft does not lock, reinsert applying moderate pressure and slowly move shaft side to side for lock to engage. Make sure switch body is still supported to prevent flexing. Press shaft firmly until it clicks into place.
5. Ensure the shaft is fully seated and in the off position.



www.americanautowire.com 856-933-0801

PART # **500332**
 DESCRIPTION:
Headlight Switch

92964649 Rev 3.0 1/10/2020

To Trim Shaft to Fit or Remove Shaft:

The headlight shaft knob should extend from the face of the mounting nut, and must allow enough clearance for the switch to turn off. If the shaft is longer than necessary for your specific dash it can be trimmed to fit. Always trim the knob end of the shaft only and follow the guidelines below for best results.

1. With the headlight switch installed, loosen the set screw and remove the knob. Make sure the switch is in the "off" position by pushing the shaft toward the back of the switch.

**Switch in OFF position
(shaft pushed all the way in)**

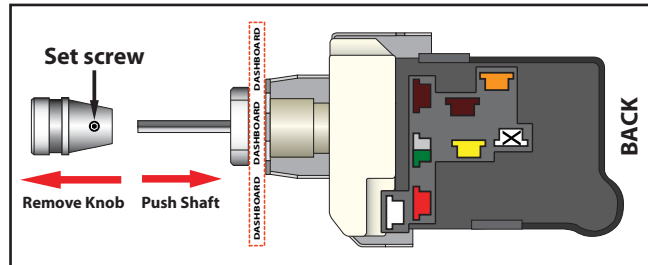

2. Set knob alongside shaft and mark the desired location for cutting on the shaft.

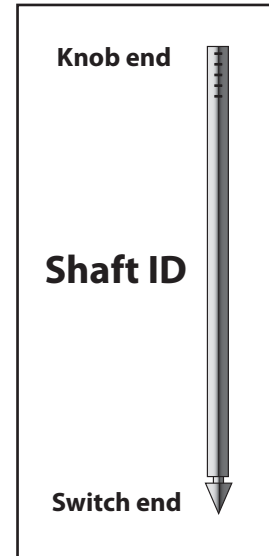
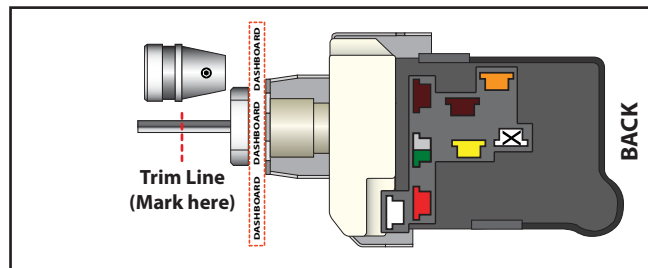

3. Remove the shaft and trim at mark. The shaft can be released from the switch by pulling it outward (toward the rear of the vehicle). Once fully in the "On" position, press and hold the release button on the base of the switch body. Once button is pressed, continue to pull the shaft outward. New switches may be tight, and it might be necessary to move the shaft side to side slightly while pulling to release.

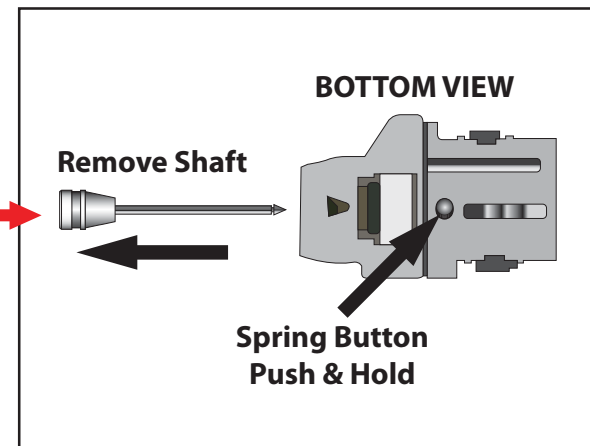
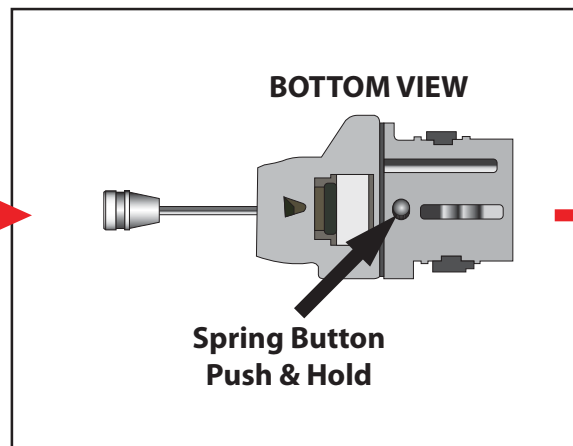
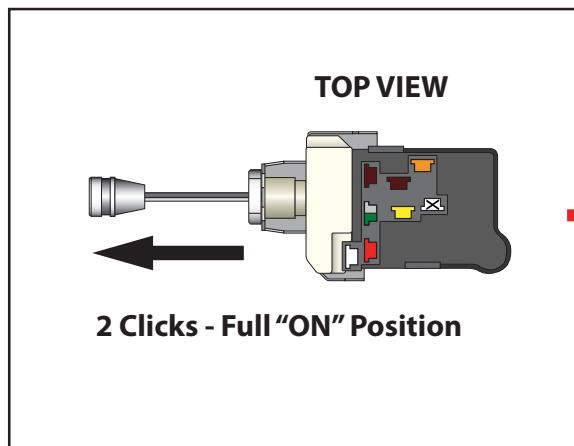

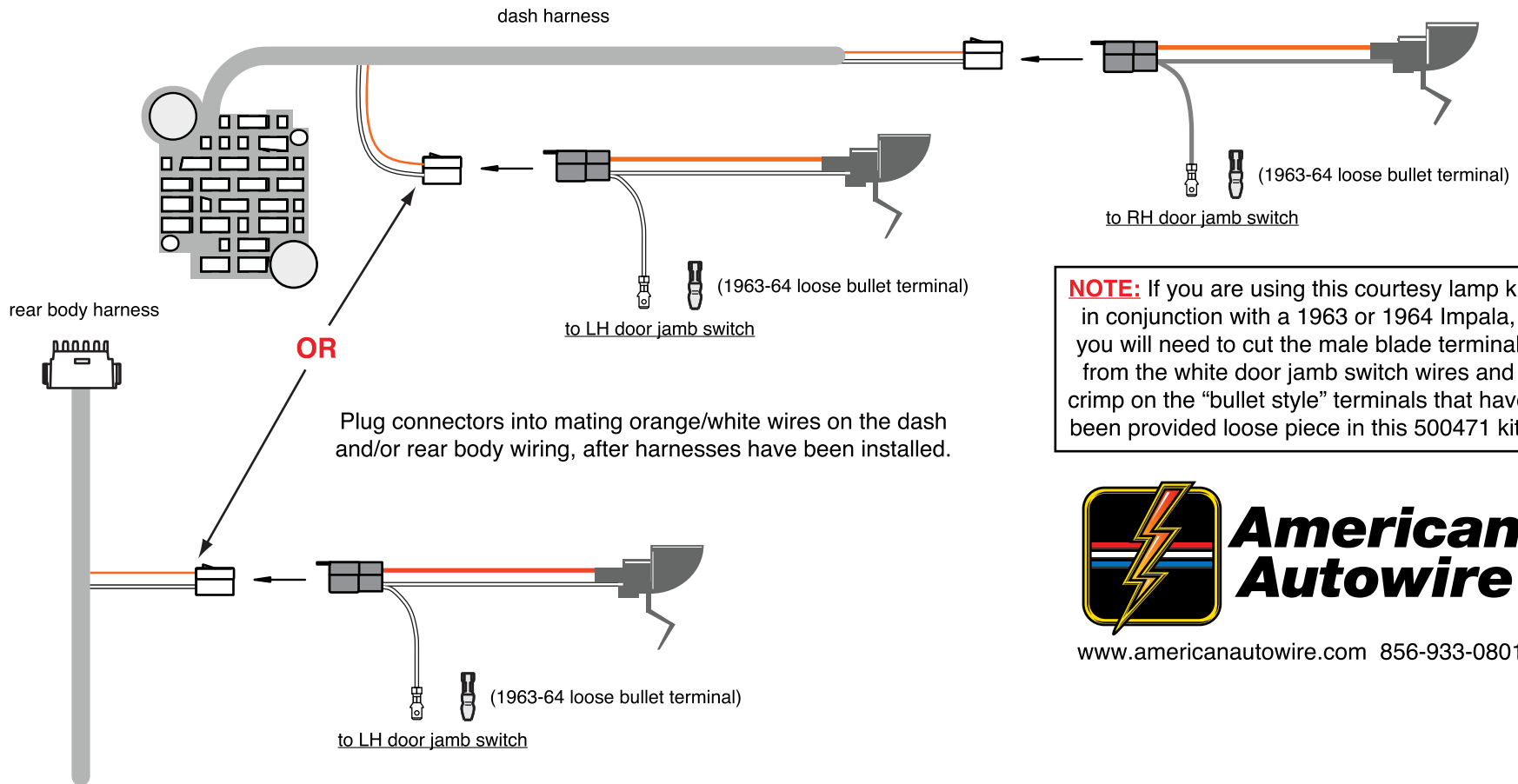

NOTE: If you are using this courtesy lamp kit in conjunction with a 1963 or 1964 Impala, you will need to cut the male blade terminal from the white door jamb switch wires and crimp on the "bullet style" terminals that have been provided loose piece in this 500471 kit.



**American
Autowire**

www.americanautowire.com 856-933-0801

NOTE: Your new underdash courtesy lamp kit uses # 631 bulbs (not included with this kit). They may be purchased at any auto parts store.

PART #	N
500471	
DESCRIPTION:	<u>Courtesy Lamp Kit</u>
92965219	Rev 3.0 12/20/2019

A  (1)
 (144.0" 6 Gauge charge wire)

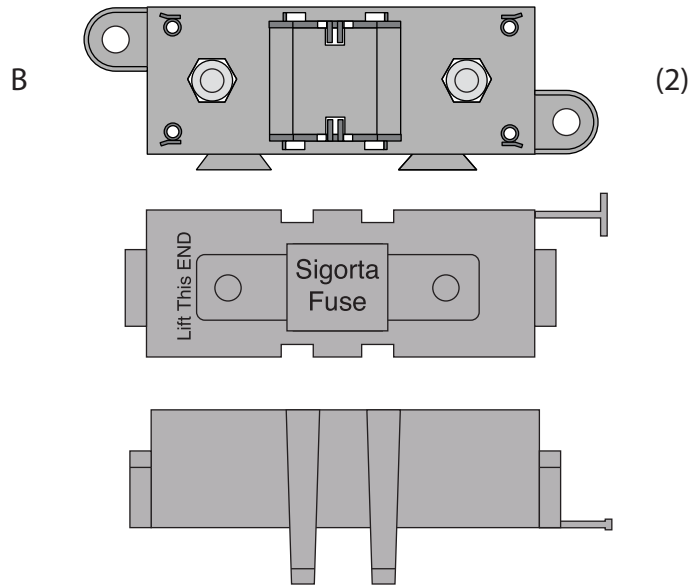

1. On this page, you will find the wire, fuse bodies, fuses, boot, ring terminals, and shrink tubing (items A through K) that are necessary to connect your alternator and main power feed for your new AAW wiring kit. Please be sure that all of the necessary components are present before starting this portion of your installation. If anything is missing, stop what you are doing and contact AAW at the number listed below right away.

2. On page 2, you will find directions for building the 2 Megafuse assemblies (items B,C and D) into one unit.

3. On page 3, you will find an overall concept of how to connect the Megafuse assemblies to your starter solenoid, alternator and main power feed of your new wiring system.

4. On page 4, you will find tips on building your charging circuit wires and assembling them and the main panel power feed wire to the Megafuse assemblies.

(Megafuse body, cover and two M8 x 1.25 nuts / lock washers)

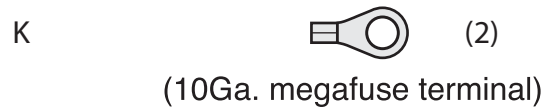
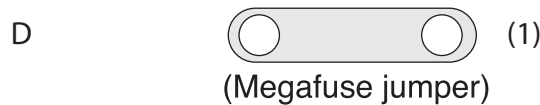
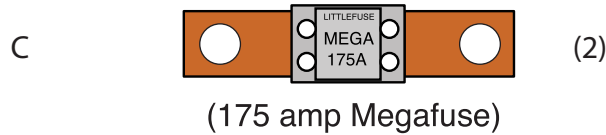

www.americanautowire.com 856-933-0801

PART # **510476** **Z**

DESCRIPTION:
 Alternator and Main Power
 Connection Kit
 Various Applications

92972153 instruction sheet rev 0.1 6/24/2019

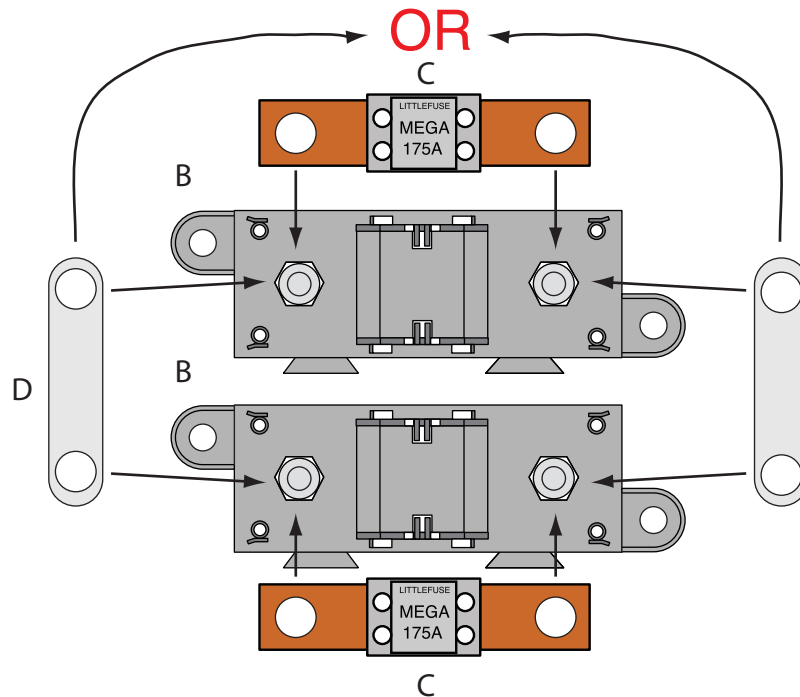

Assembling the (2) Megafuse assemblies

NOTE: Find a suitable place, as close to the battery power source as possible, under the hood of your vehicle to mount the completed Megafuse assemblies. Keep in mind that you have 12 feet of 6Ga. charging wire, and that the main power feed coming from your panel or bulkhead connection must also be able to reach the assembly.

1. Take the two Megafuse bodies and covers (items B) and snap them together. Remove the 4 nuts and lock washers from the studs on the fuse body assemblies.
2. Install the Megafuse jumper (item D above) over two of the studs on the Megafuse bodies. It is very important that the jumper **MUST BE** assembled on the side that is going to connect to your main power connection (starter solenoid or battery feed).
3. Notch top cover to clear jumper D as shown at right.
4. Snap one 175amp fuse (items C) onto the studs of each of the two Megafuse bodies (items B), over the jumper, then loosely re-attach the 4 nuts and lock washers back onto the assembled Megafuses. The fuse assemblies are ready to install into your vehicle.

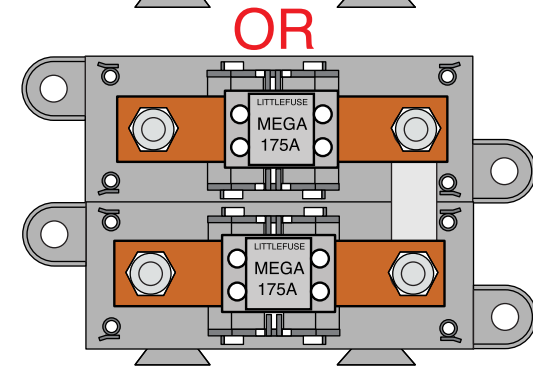
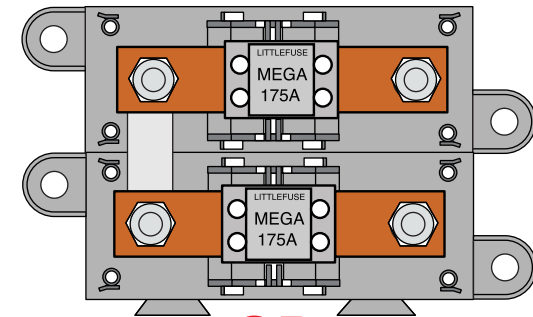

Assembled Megafuses

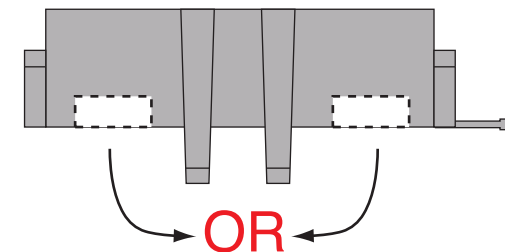

Notched Cover

PART #

510476

Z

DESCRIPTION:

Alternator and Main Power
Connection Kit
Various Applications

92972153 instruction sheet rev 0.1 6/24/2019

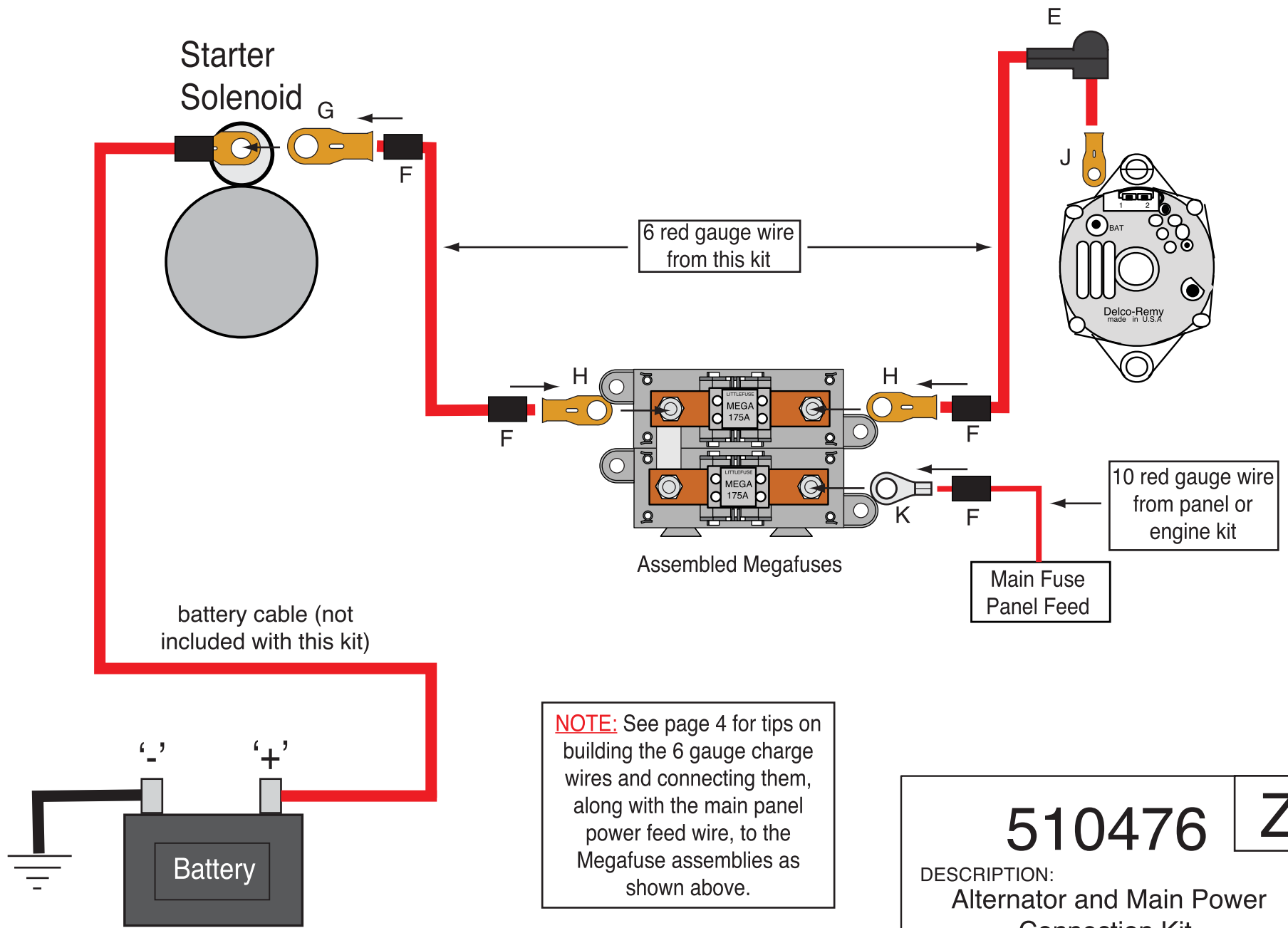

NOTE: See page 4 for tips on building the 6 gauge charge wires and connecting them, along with the main panel power feed wire, to the Megafuse assemblies as shown above.

<h1>510476</h1>	<h1>Z</h1>
<p>DESCRIPTION: Alternator and Main Power Connection Kit Various Applications</p>	
<p>92972153 instruction sheet rev 0.1 6/24/2019</p>	

Building the 6Ga. charge wires and connecting them and the main panel power feed wire to the Megafuse assemblies:

NOTE: Make sure that your battery is disconnected! You will need to install the preassembled Megafuses from page 2 in your vehicle to start this part of the installation.

1. Pre-cut item F shrink tubing into (6) 1.00" - 1.25" pieces.
2. Take the 12-foot piece of 6Ga. red wire from this kit and route it from your starter (or other battery feed) over to the area where you have mounted your Megafuse and cut it to length. Strip the insulation on each end back 1/2". Install 2 pieces of shrink tubing F onto the wire. At the starter end, crimp and solder (1) of terminal G onto the wire. At the Megafuse end, crimp and solder (1) of terminal H onto the wire. Slide the shrink tubing over the terminals and heat it up to shrink it down.
3. Take the remaining portion of the 12-foot piece of 6Ga. red wire from this kit and route it from your alternator over to the area where you have mounted your Megafuse and cut it to length. Strip the insulation on each end back 1/2". Install 1 piece of shrink tubing F onto the wire. At the alternator end, slip on boot E as shown on page 3, then crimp and solder (1) of terminal J onto the wire. At the Megafuse end, crimp and solder (1) of terminal H onto the wire. Slide the shrink tubing over terminal H and heat it up to shrink it down.
4. Take the 10Ga. red main power feed wire from your engine or panel sub-kit and route it over to the area where you have mounted your Megafuse and cut it to length. Strip the insulation back 3/8". Install 1 piece of shrink tubing F onto the wire, then crimp and solder (1) of terminal K onto the wire.
5. Remove the 4 loosely tightened nuts and lock washers from the assembled Megafuses, then using the drawing on page 3 as a guide, install your pre-assembled wires from steps 2-4 above. Re-install the 4 nuts and lock washers onto the assembled Megafuses and tighten them down. This part of your installation is now complete.

510476

Z

DESCRIPTION:

**Alternator and Main Power
Connection Kit
Various Applications**

92972153 instruction sheet rev 0.1 6/24/2019

CONNECTOR "D" DETAIL:

NOTE: The wire colors below are shown looking into the face of the connector with the wires plugged in from behind.

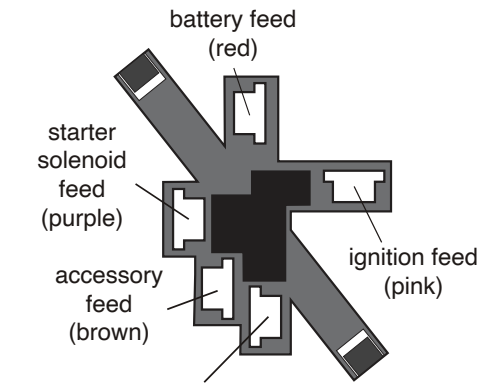

bulb check ground
(Momentary ground for temperature warning light bulb check. Only used on select vehicles)

IGNITION SWITCH DETAIL:

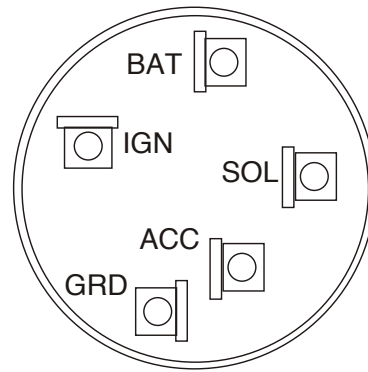

Connector "D" is pre-wired on the dash harness. This is not a loose connector.

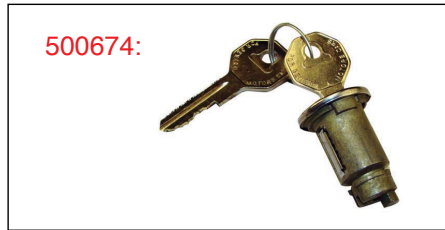
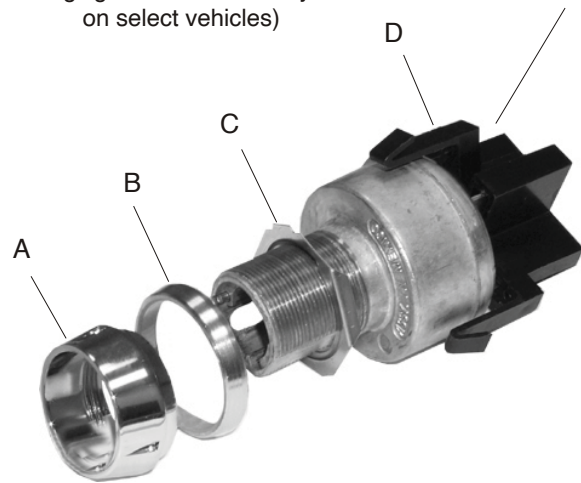

INSTALLATION:

NOTE: This package may include a copper lamp holder bracket. That bracket is not used in this application and its installation can be ignored.

1. Due to the nature of the chrome plating on threaded collar A, AAW recommends threading the nut on and off of the switch by hand a few times to clean up the threads before installing the switch into your dash.
2. Plug in connector D from the dash wiring harness (bag G).
3. Install the back-up nut C onto the switch. The depth of this nut will have to be determined when mounting the switch.
4. Insert the switch into the hole in the dash panel.
5. Install your original dash bezel plate.
6. Slide on collar B.
7. Screw on threaded collar A
8. Insert your original or New AAW lock cylinder into the new switch to complete your installation.

NOTE: AAW has new lock cylinders with the correct GM style keys for this ignition switch. Check the table below for the correct key and tumber for your vehicle.

CLASSIC UPDATE KIT PART #	CLASSIC UPDATE APPLICATION	KEY & LOCK CYLINDER PART # REQUIRED
500423	1955-56 Chevy Car	500672
500434	1957 Chevy Car	500672
500481	1955-59 Chevy Truck	500672
510217	1959-60 Chevy Impala	500672
510063	1961-64 Chevy Impala	500672
510267	1953-62 Chevy Corvette	500672
500467	1947-55 Chevy Truck	500674
500560	1960-66 Chevy truck	500674
510360	1965 Chevy Impala	500674
510372	1966-68 Chevy Impala	500674

NOTE: Please keep in mind that this is an upgraded switch, not an original replacement, and as such, the flat side on this switch may be in a different location than was your original. If you mount this new AAW switch in your dash and the flat side is in fact in a different location, the key may not line up as the original did. This will not alter the performance of the switch in any way. If you wish for your key to line up as it did in the OEM application, you will need to file out the flat spot in your original dash opening so that the switch can be rotated to the correct position. Once the backing nut C is set so that the depth of the switch is correct for your application, and bezel nut A is firmly tightened, the switch will be secure and will not rotate.



**American
Autowire**

www.americanautowire.com 856-933-0801

IGNITION SWITCH
Classic Update Series
VARIOUS APPLICATIONS

510632

92972596 instruction rev 1.0 10/10/2024

Most switches supplied with Classic Update and Universal Kits ship with the shaft pre-installed. In many instances, the switch can be installed without removing the shaft, but in some cases the switch shaft may need to be trimmed to fit your specific dash. In this situation, reference Trim to Fit instructions on the back of this page for details.

To install your new headlight switch:

1. Install the switch from behind the dash, and align the switch body with the mounting hole. The switch body has an alignment tab that must line up with the notch in the dashboard mounting hole.

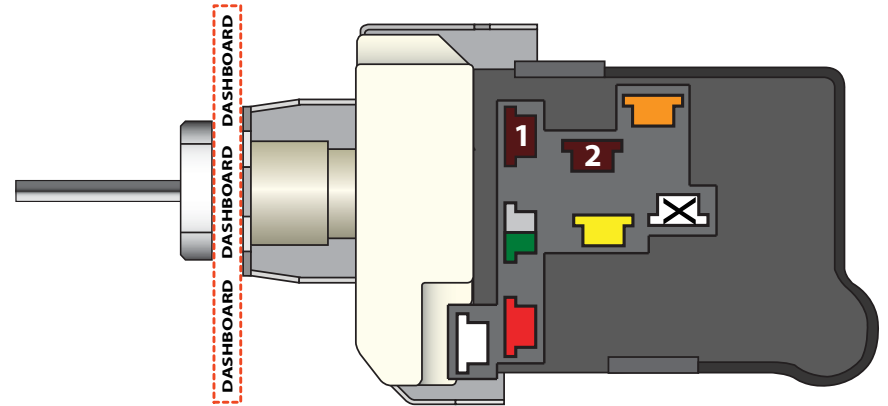
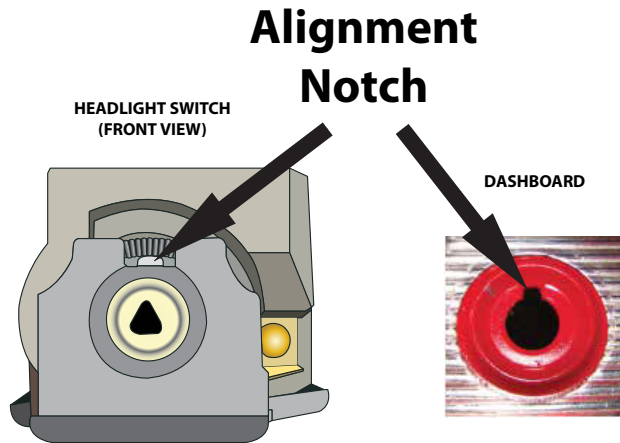

1	Parking Lights - Stay on with headlights
2	Tail Lights - On in the park and headlight positions
	Fused Battery Feed - For park, tail and dash lamps
	Headlight Feed - Power to the headlight dimmer switch
	12V Battery Feed - Unfused power to the switch for headlights
	Courtesy Ground - Ground feed to the dome and courtesy lights
	Part-time Parking Lights - Turns off when the headlights are on (Not supported by all kits)
	Dash Lights - Output to the dash light fuse or lights

2. Install the switch mounting nut and tighten.
3. Gently press shaft into switch until it stops, then press firmly until it "clicks." Pull shaft back out to confirm it is seated correctly. The shaft should be locked into place inside switch.
4. If the shaft does not lock, reinsert applying moderate pressure and slowly move shaft side to side for lock to engage. Make sure switch body is still supported to prevent flexing. Press shaft firmly until it clicks into place.
5. Ensure the shaft is fully seated and in the off position.



www.americanautowire.com 856-933-0801

PART # **500332**
 DESCRIPTION:
Headlight Switch

92964649 Rev 3.0 1/10/2020

To Trim Shaft to Fit or Remove Shaft:

The headlight shaft knob should extend from the face of the mounting nut, and must allow enough clearance for the switch to turn off. If the shaft is longer than necessary for your specific dash it can be trimmed to fit. Always trim the knob end of the shaft only and follow the guidelines below for best results.

1. With the headlight switch installed, loosen the set screw and remove the knob. Make sure the switch is in the "off" position by pushing the shaft toward the back of the switch.

**Switch in OFF position
(shaft pushed all the way in)**

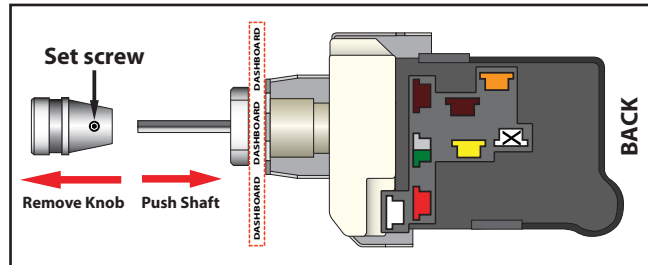

2. Set knob alongside shaft and mark the desired location for cutting on the shaft.

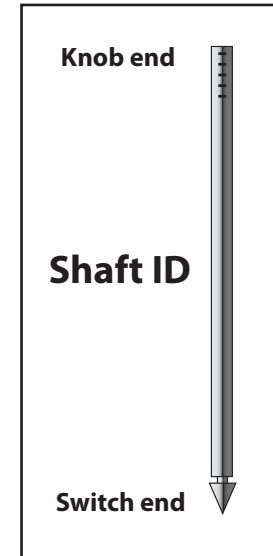
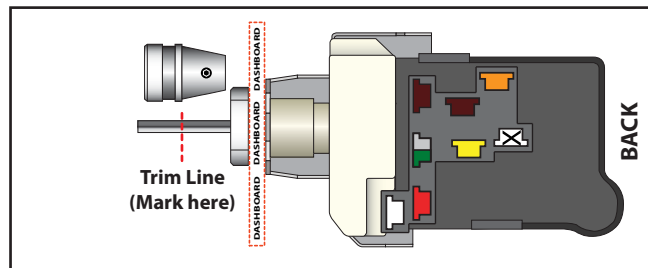

3. Remove the shaft and trim at mark. The shaft can be released from the switch by pulling it outward (toward the rear of the vehicle). Once fully in the "On" position, press and hold the release button on the base of the switch body. Once button is pressed, continue to pull the shaft outward. New switches may be tight, and it might be necessary to move the shaft side to side slightly while pulling to release.

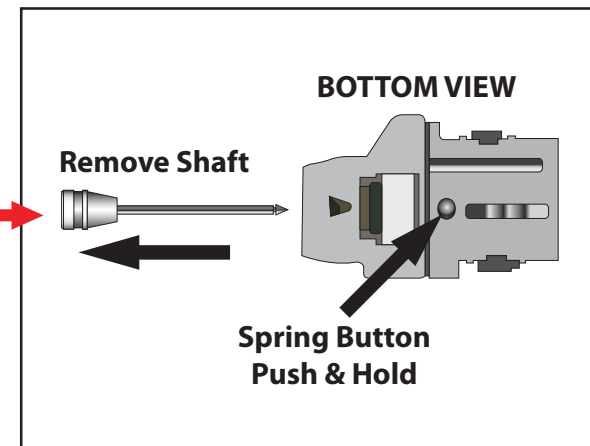
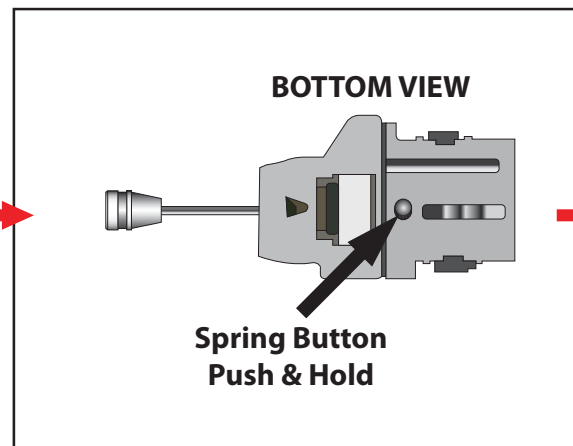
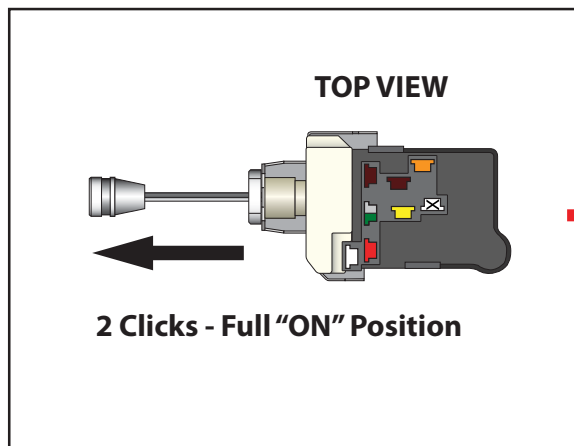

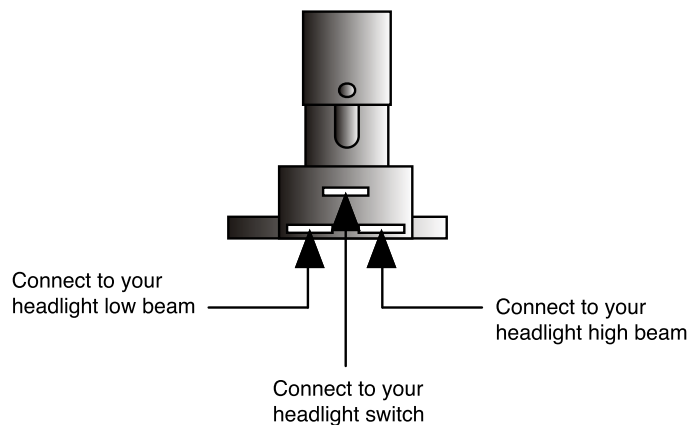

Connect the Dimmer Switch wires as shown above.

1. The top center terminal of the Dimmer Switch is connected to the Headlight switch.
2. The terminal on the right side is connected to your headlight high beam terminal.
3. The terminal on the left side is connected to your headlight low beam terminal.



www.americanautowire.com 856-933-0801

PART #

500042

DESCRIPTION:

DIMMER SWITCH

92964573 Rev 3.1 12/5/2014

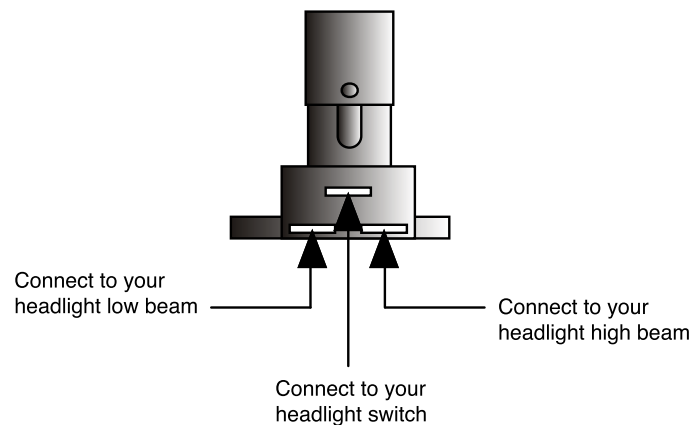

Connect the Dimmer Switch wires as shown above.

1. The top center terminal of the Dimmer Switch is connected to the Headlight switch.
2. The terminal on the right side is connected to your headlight high beam terminal.
3. The terminal on the left side is connected to your headlight low beam terminal.



www.americanautowire.com 856-933-0801

PART #

500042

DESCRIPTION:

DIMMER SWITCH

92964573 Rev 3.1 12/5/2014